

Busbar System VT

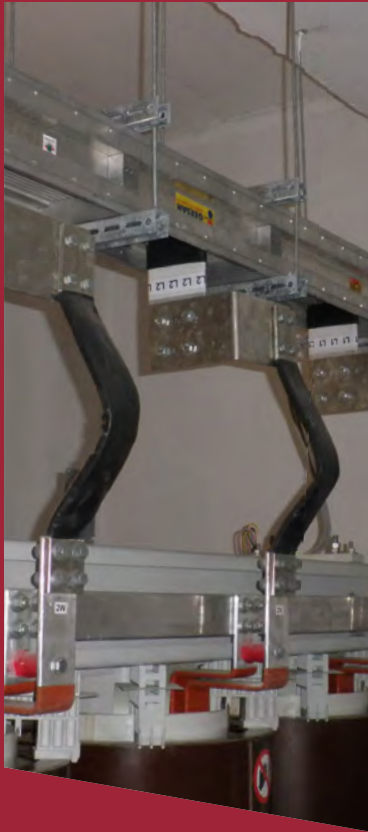

Simple
Space
Reliable
Secure



Resin busbar trunking system

CONTENTS

Preface to Vibitech	3
>>>> Busbar System VT IP 68	
Description of VT	5
VT Features	6
VT Components	7
VT Fire barrier	8
Applicable rules and regulations	8
VT Declaration of Conformity	9
VT Technical specifications	10
Presentation of VT Standard parts	12
References	15
Certificate	16
Contact	17

Responsible for contents: Katerina Link
Images: VIBITECH GmbH
Layout, Printing: COVI.DE

PREFACE TO VIBITECH



VIBITECH stands for Valued Intelligent Busbar Industrial Technology. The newly set up company Vibitech GmbH began developing low voltage busbar trunking systems in 2011. Later on, the management of Vibitech GmbH purposefully used its longstanding experience in the design, production, and sales of low voltage busbar trunking systems and established a production site in Stralsund to meet the quality standards “Made in Germany”.

or aluminium conductors up to 5000A with 4 or 5 poles.

The use of epoxy-resin-based polymer concrete provides a high IP 68 degree and predetermines the system for specific indoor and outdoor service conditions.

The busbar trunking system VT facilitates transmission and distribution of electrical energy within a building or any other facilities completely.



Vibitech successfully completed the procedure for certification in accordance with the requirements of ISO 9001 in 2013. The company purchases raw materials for processing only from suppliers who can provide top-quality materials.

The system VT with busbars embedded in polymer concrete is part of the product range. The trunking shall be suitable for use up to 1000V. It can be delivered with copper conductors up to 6000A rated current

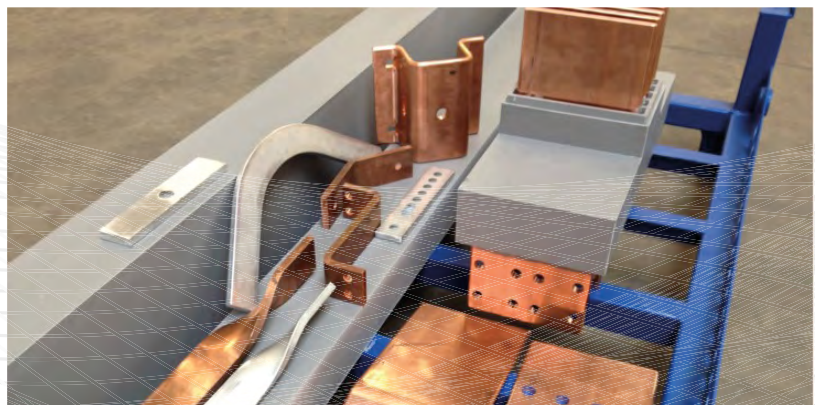

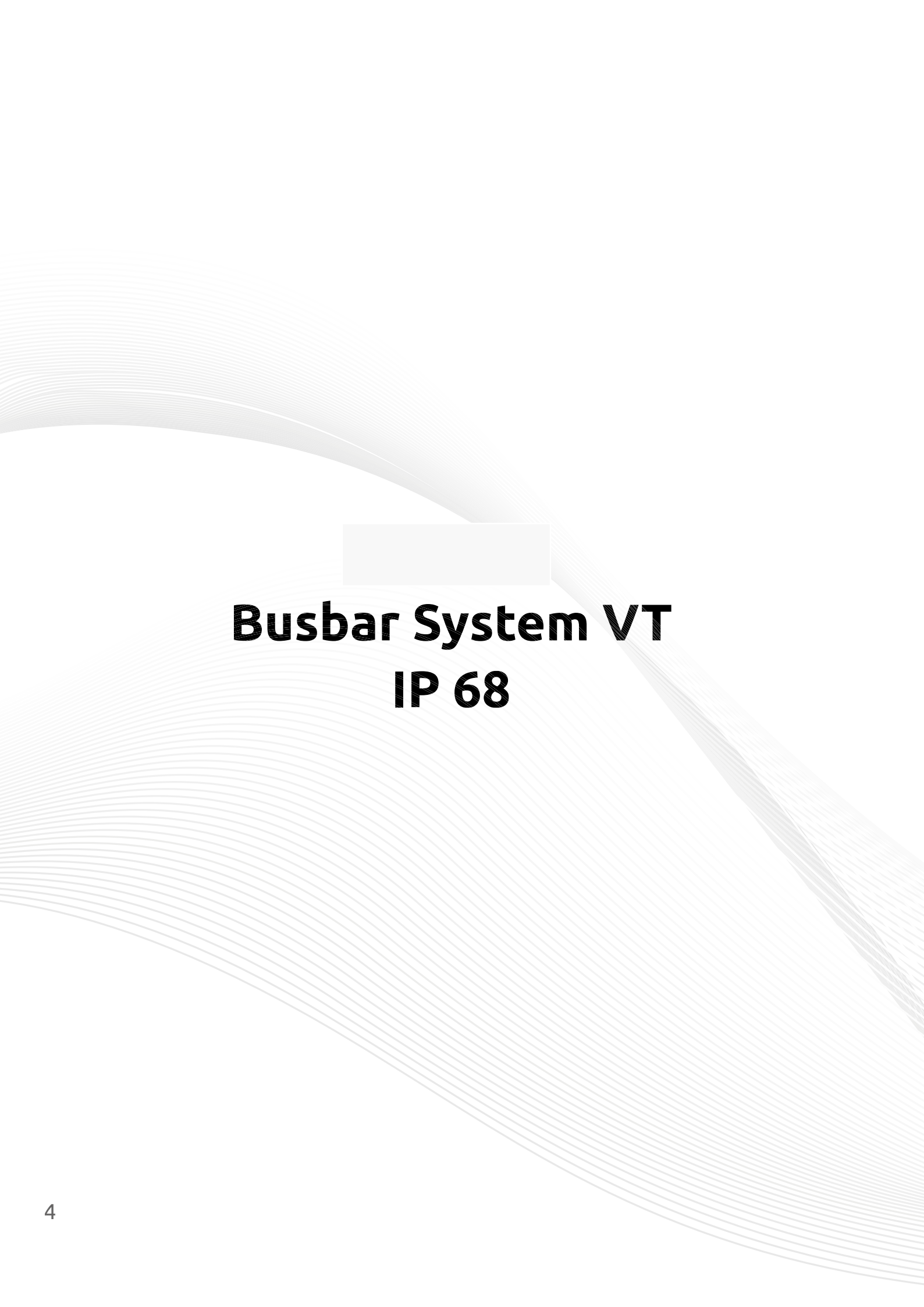

**Busbar System VT
IP 68**



DESCRIPTION OF VT

Epoxy cast resin busbars have special properties. They are extremely weatherproof and designed for an operating temperature range from $-40\text{ }^{\circ}\text{C}$ to $+40\text{ }^{\circ}\text{C}$. It mainly serves to connect transformers to electric cabinets and the switchboard system e.g. low voltage main distributions, sub-distributions,

and the switching system to the standby set. Busbars with IP 68 protection degree can be used in extreme environments e.g.:

- Outdoors
- Chemical industry
- Very humid environments
- Subways
- Tough ambient conditions

VT FEATURES

Busbars are generally made from either copper or aluminium. Although copper is an excellent conducting material, its high price and weight are disadvantageous. With adequate electric properties, Aluminium is lighter than copper, and it is sold at lower prices per kilogram. But on the other side, aluminium quickly forms oxide film $4Al + 3O_2 = 2Al_2O_3$, which causes an increased contact resistance when two elements compound. In addition, direct contact between bare aluminium and copper can result in so-called galvanic or contact corrosion, which could cause serious damage to the metals. To avoid any adverse effects, the surface of the aluminium busbar is electrogalvanized. A specialised operator company removes the oxide film chemically and applies a NiSn layer onto the surface. The contact resistance value is thus perma-

nently ensured and the copper busbar connections will be absolutely safe.

In relation to cable systems, busbar design systems provide incontestable and distinct advantages as for instance: effective energy transmission at smallest places and 90° elbows for all system sizes.

The high protection degree and the excellent wire ingress protection through polymer concrete insulation enable reliable operation and long lifecycles even under extreme conditions.

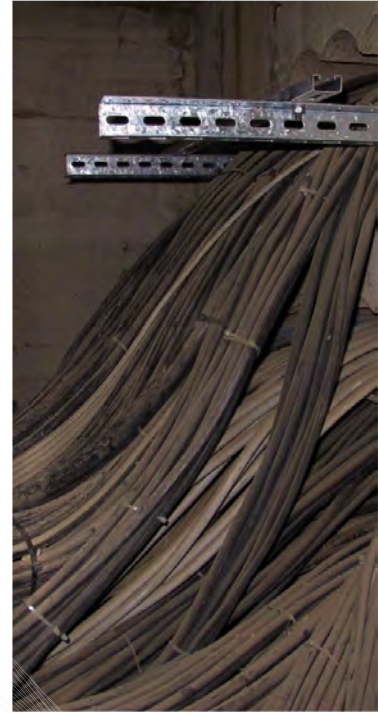

Insted of harnesses ...

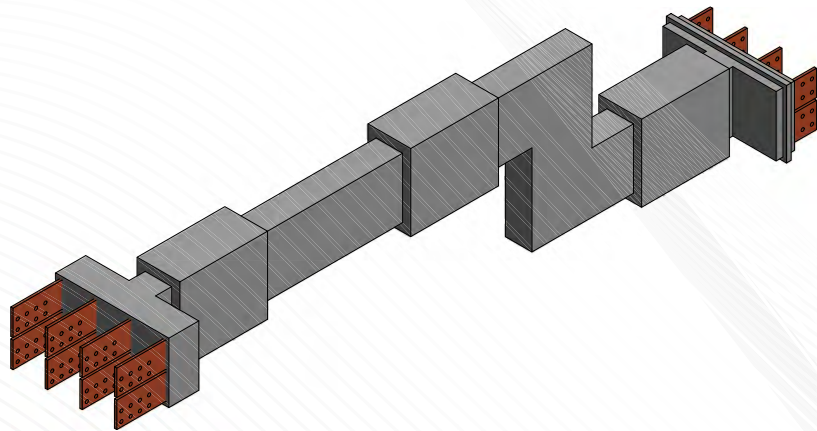

... compact method of construction with busbars systems

VT COMPONENTS

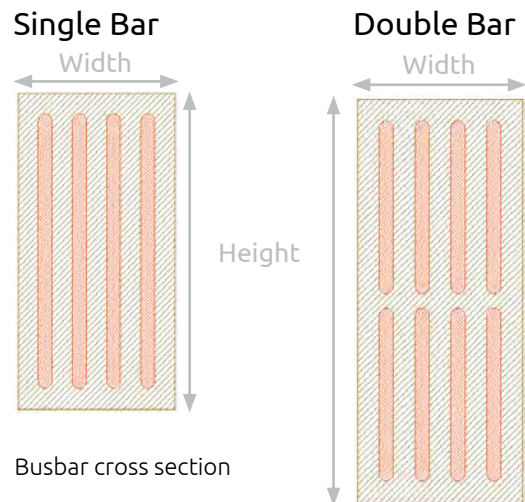
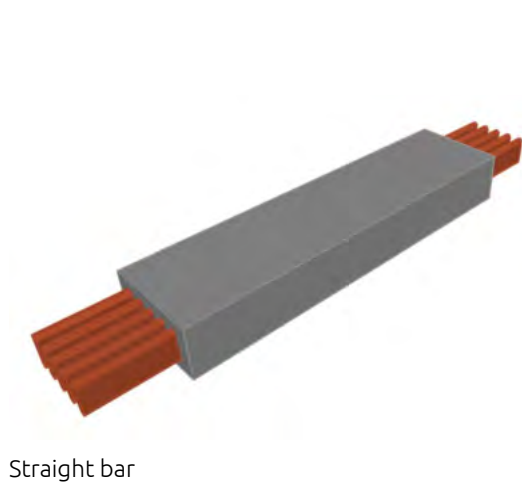

System number	Single/Double Bar		Height, mm		Width, mm	
	Al	Cu	Al	Cu	4 pol.	5 pol.
800		1		86	107	128
1000		1		96	107	128
1250		1		116	107	128
1600	1	1	186	146	107	128
2000	1	1	216	186	107	128
2500	1	1	246	216	107	128
3150	2	1	352	246	107	128
4000	2	2	412	352	107	128
5000	2	2	472	412	107	128
6000		2		472	107	128

Geometric dimensions of busbar trunks with aluminium from 1600A to 6000A and copper from 800A to 6000A.

VT FIRE BARRIER



The fire barrier is a major aspect in building services. It guarantees the fire-resistance rating of fire walls or ceilings up to 120 minutes. In the event of fire, continuous power supply is to be ensured. In cooperation with the MFPA Leipzig testing laboratory, the products made by Vibitech passed all testing successfully.

Fire barrier testing for the busbars was carried out in compliance with DIN 4102-9 and following DIN EN 1366-3.

All test objects were tested both in horizontal and in vertical position. The tests verified that the busbars may be in-

stalled into fire walls and ceilings without any reservations. Aluminium busbar trunks with EI 90 do not require any sheathing. To ensure EI 120 protection for copper and aluminium designs, a sheathing with PROMAXON fire resistance boards (thickness = 20mm, length = 395mm) is required.

When manufacturing with IP55 protection, PROMAXON fire resistance boards are always required in order to fulfil the provisions of the EI 120 fire-resistance rating.

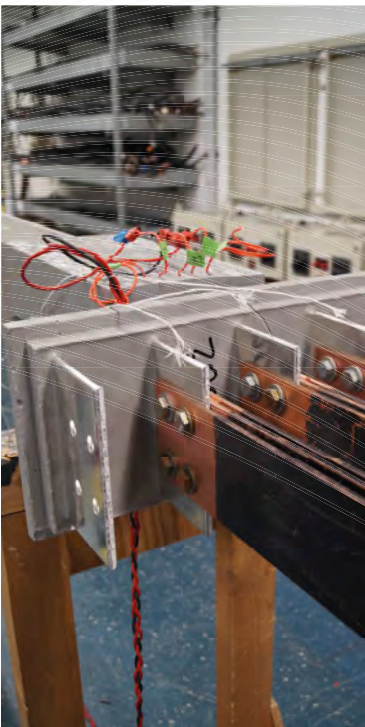

APPLICABLE RULES AND REGULATIONS

The system has been designed and tested in accordance with EN 61439, part 1 and 6. Design specifications are available for the entire system and enable certification in compliance with LOVAG (EU) and GOST (RUSSIA).

VT DECLARATION OF CONFORMITY



KONFORMITÄTSERKLÄRUNG

Declaration of Conformity

Wir (Name des Anbieters): **Vibitech GmbH**
We (supplier's name):

Diese Konformitätserklärung entspricht der Europäischen Norm EN 45014 „Allgemeine Kriterien für Konformitätserklärungen von Anbietern“. Die Grundlage Kriterien sind internationale Dokumente, insbesondere ISO/IEC – Leitfaden 22,1982, „Informations on manufacturer's declaration of conformity with standards or other technical specifications“.

This Declaration of Conformity is suitable to the European Standard EN 45014 „General Criteria for supplier's declaration of conformity“. The basis for the criteria has been found in international documentation, particularly in: ISO/IEC Guide 22, 1982, „Informations on manufacturer's declaration of conformity with standards or other technical specifications“.

Anschrift: Rostocker Chaussee 46
address: DE – 18439 Stralsund
Deutschland/Germany

erklären in alleiniger Verantwortung, dass das Produkt:
declare under our sole responsibility that the product:

VT1600AL ... VT5000AL
VT1600CU ... VT6300CU

(Bezeichnung, Typ oder Modell, Los-, Chargen- oder Serien Nr., möglichst Herkunft und Stückzahl) / (Name, type or model, batch or serial number, possibly sources and number of items)

auf das sich diese Erklärung bezieht, mit der/den folgenden Norm(en)
oder normativen Dokument(en) übereinstimmt.
to which this declaration relates is in conformity with the following
standard(s) or other normative document(s).

DIN EN 61439-1 VDE 0660-600-1:2010-06
IEC 61439-1:2009, modifiziert
DIN EN 61439-6 VDE 0660-600-6:2013-06
IEC 61439

(Titel und/oder Nr. sowie Ausgabedatum der Norm(en) oder der anderen normativen Dokumente/Titel and/or number and date of issue of the standard(s) or other normative document(s))

Gemäß den Bestimmungen der Richtlinie(n) (falls zutreffend)
Following the provisions of Directive(s) (if applicable)

Niederspannungsrichtlinie Low Voltage Directive

Stralsund 23 03 2015

(Ort und Datum der Ausstellung/
Place and date of issue)

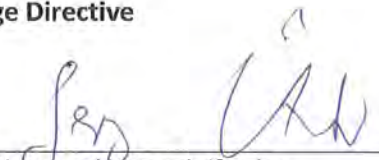
(Name und Unterschrift oder
gleichwertige Kennzeichnung des
Befugten/name and signature or
equivalent marking of authorised
person)

VT TECHNICAL SPECIFICATIONS

Rated current:	Aluminium busbar systems 1600A – 5000A, Copper busbar systems 800A – 6000 A.
Rated operating voltage:	1000 V, AC
Configuration:	System with 4 or 5 poles
Protection degree:	Without tap off boxes IP68 With tap off boxes IP55
Insulating material:	Epoxy resin
Ambient temperature range:	- 40 °C to + 40 °C

BUSBAR SYSTEM WITH AL-CONDUCTORS, 4 POLES

Type	VT	1600	2000	2500	3150	4000	5000
Rated current I_e	A	1600	2000	2500	3150	4000	5000
Cross-section of conductor	mm ²	1110	1350	1590	2230	2710	3190
Rated peak withstand current I_{pk}	kA	>100*	143	143	220	220	220
Rated short-time withstand current I_{cw} (t = 1s)	kA	>50*	65	65	100	100	100
Weight	kg/m	41,34	48,85	56,06	87,39	102,41	117,51

BUSBAR SYSTEM WITH AL-CONDUCTORS, 5 POLES

Type	VT	1600	2000	2500	3150	4000	5000
Rated current I_e	A	1600	2000	2500	3150	4000	5000
Cross-section of conductor	mm ²	1110	1350	1590	2230	2710	3190
Rated peak withstand current I_{pk}	kA	>100*	143	143	220	220	220
Rated short-time withstand current I_{cw} (t = 1s)	kA	>50*	65	65	100	100	100
Weight	kg/m	49,58	58,58	67,64	104,78	122,80	140,92

BUSBAR SYSTEM WITH CU-CONDUCTORS, 4 POLES

Type	VT	1600	2000	2500	3150	4000	5000	>6000*
Rated current I_e	A	1600	2000	2500	3150	4000	5000	6000
Cross-section of conductor	mm ²	790	1110	1350	1590	2230	2710	3190
Rated peak withstand current I_{pk}	kA	>100*	143	176	176	220	220	280
Rated short-time withstand current I_{cw} (t = 1s)	kA	>50*	65	80	80	100	100	116
Weight	kg/m	50,98	69,02	82,53	96,03	142,74	169,77	196,87

BUSBAR SYSTEM WITH CU-CONDUCTORS, 5 POLES

Schienen - Typ	VT	1600	2000	2500	3150	4000	5000	>6000*
Rated current I_e	A	1600	2000	2500	3150	4000	5000	6000
Cross-section of conductor	mm ²	790	1110	1350	1590	2230	2710	3190
Rated peak withstand current I_{pk}	kA	>100*	143	176	176	220	220	280
Rated short-time withstand current I_{cw} (t = 1s)	kA	>50*	65	80	80	100	100	116
Weight	kg/m	62,13	84,18	100,68	117,24	173,24	206,99	240,12

* The tests have been not completed.

PRESENTATION OF VT STANDARD PARTS

The product range includes a variety of different parts, which allow effective and reasonably priced routing of trunks. Trunk routes are usually very compact. Vibitech therefore provides customised parts if required.

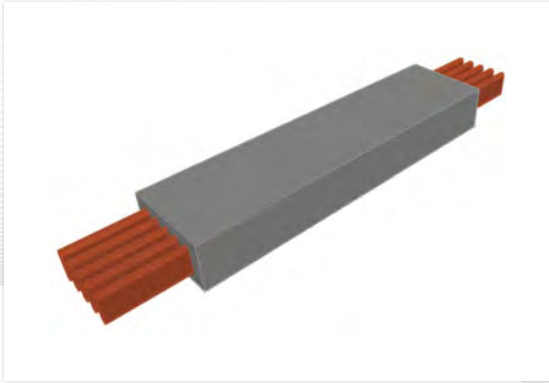

Direct bus element

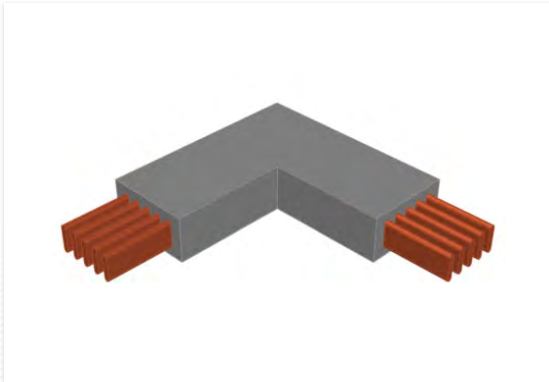

Horizontal elbow

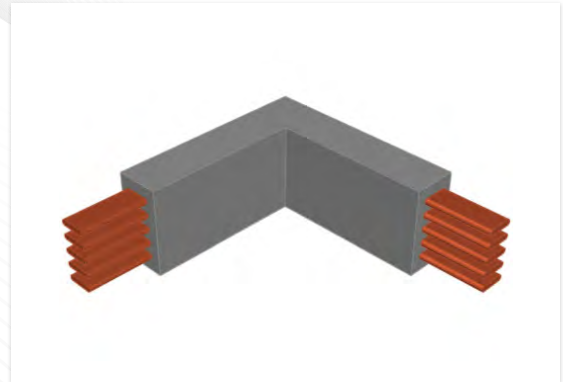

Vertical elbow

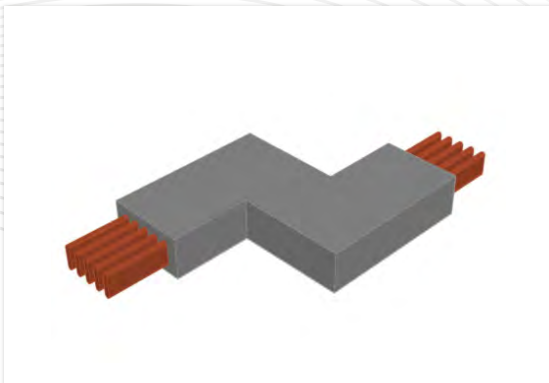

Horizontal Z-element

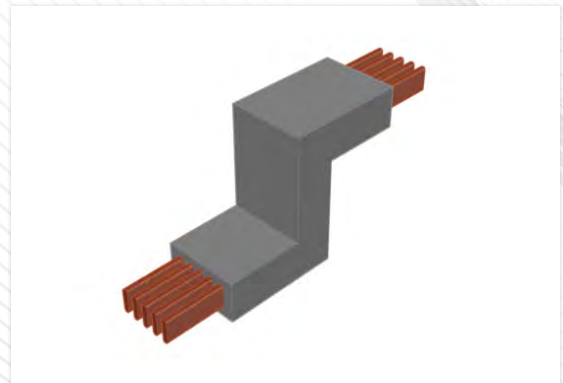

Vertical Z-element

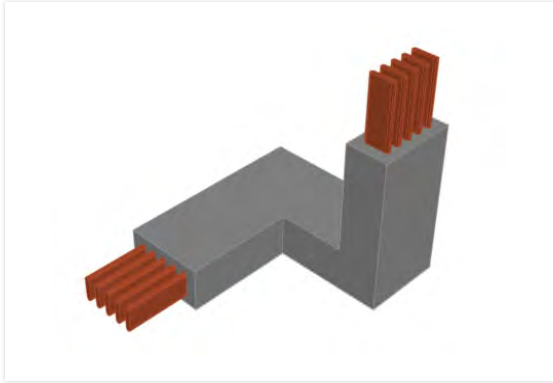

Floor up

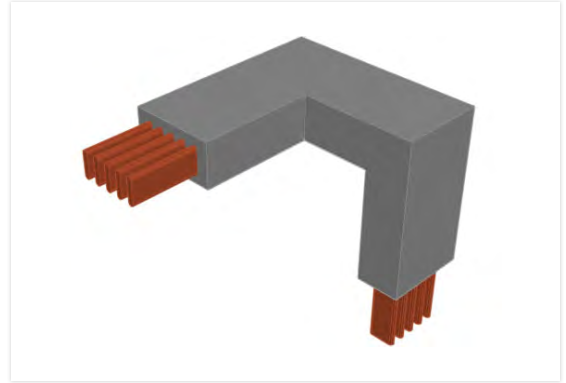

Floor down

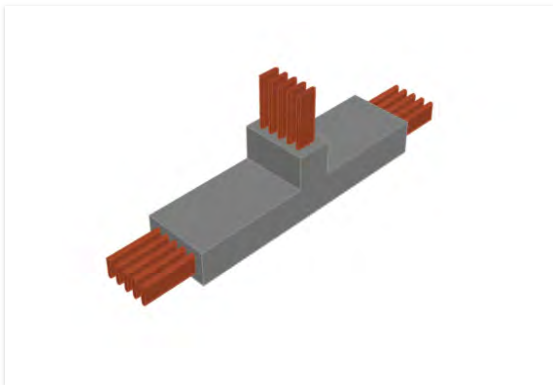

T-element

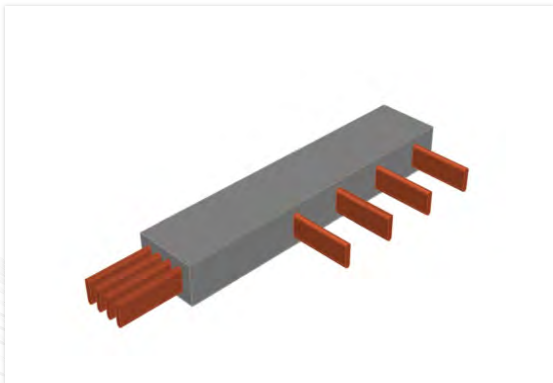

Horizontal feed unit

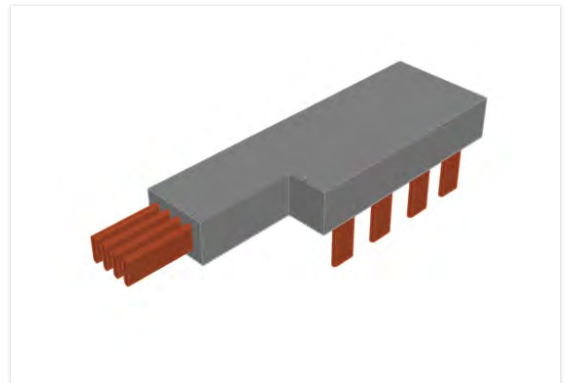

Vertical feed unit

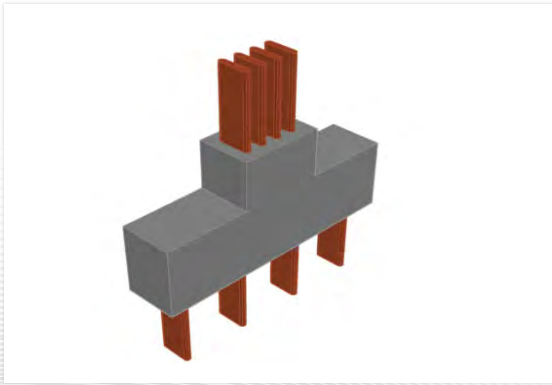

Standard feed unit

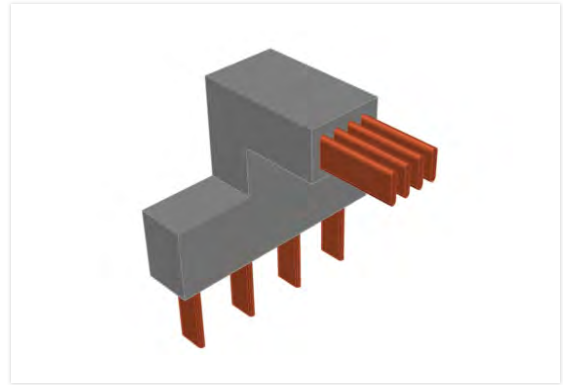

Connecting feed unit

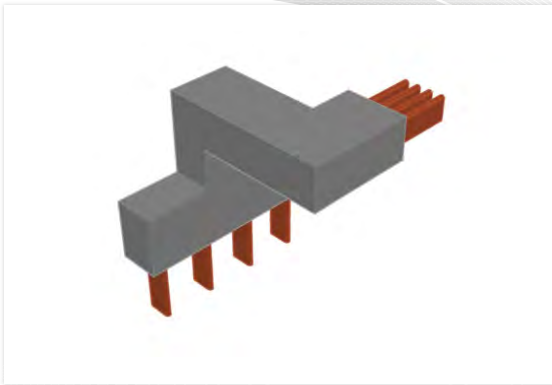

Feed unit with elbow right

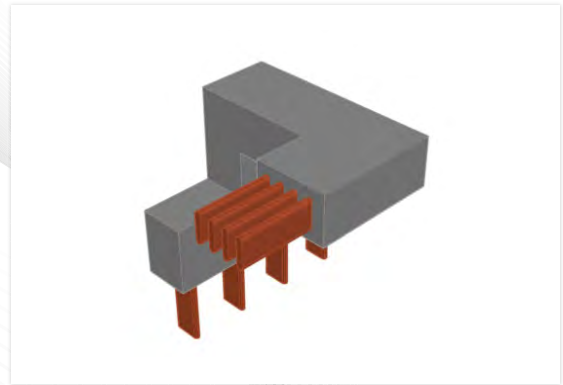

Feed unit with elbow left

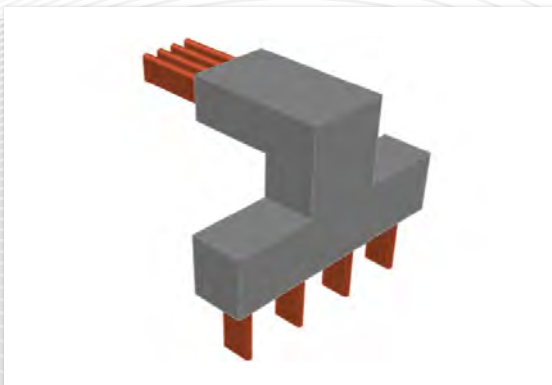

Feed unit, backward

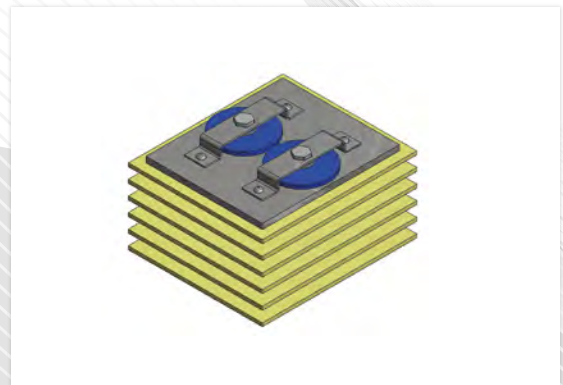

Connector

REFERENCES

MEBE | 2500 A, Cu, (L1, L2, L3 PEN) shopping centre in Moscow. From transformer, to switching gear.



BOSCH MOSKAU | 2500 A, Cu, (L1, L2, L3 PEN). Power supply of the main BOSCH office in Moscow.



BOSCH SAMARA | 2500 A, Cu, (L1, L2, L3 PEN) for the BOSCH headquarter in Samara.

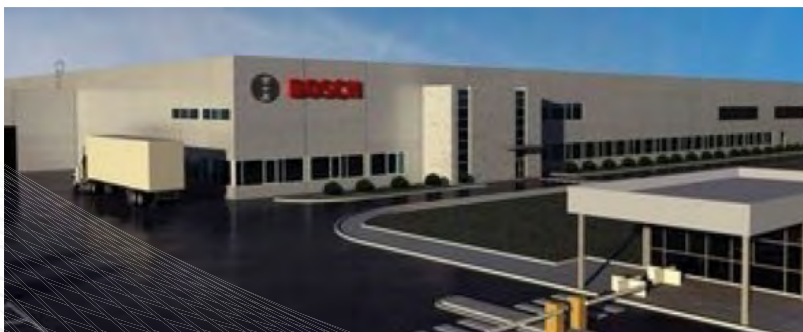

Kooperativnaja Str. | 4000 A, Cu, (L1, L2, L3 PEN). Power supply for housing estate in Moscow, 4 lines from transformer to switchgear cabinet.



NEBO | 2500 A and 2000 A, AL, (L1, L2, L3 PE, N). Power supply for the shopping centre in Nizhny Novgorod.



CERTIFICATE (ISO 9001 UND GOST)



CERTIFICATE

This is to confirm that the organisation



Vibitech GmbH
Rostocker Chaussee 46
18437 Stralsund
Germany

has implemented and maintains a Management System
in accordance with the standard

DIN EN ISO 9001:2008

The scope of the certification covers:

**Development, production and sales of busbar systems as well as
metal working of copper and aluminium alloys**

This certificate is valid until 2016-11-21
and is subject to annual surveillance audits.

Registration Number: 5016247/QM/11.13

Audit report: 5016247-9100-0001/186526

VDE Prüf- und Zertifizierungsinstitut GmbH
VDE Testing and Certification Institute
Certification

Kupf Noß
Date: 2013-11-22

Merianstraße 28, 63069 Offenbach, Germany
Telefon: +49 69 83 06-0, Telefax: +49 69 83 06-555
E-Mail: vde-institut@vde.com, <http://www.vde-institut.com>
VDE certificates are valid only when published on:
<http://www.vde.com/certificate>



Deutsche
Akkreditierungsstelle
D-ZM-12061-02-01

VDE
INSTITUT



CONTACT

VIBITECH GmbH
Rostocker Chaussee 46
D-18437 Stralsund
Germany

Offering office
Katerina Link

Phone: +49 3831 445 80 14
Fax: +49 3831 445 8029
e-mail: info@vibitech.de
Web: www.vibitech.de
Skype: VIBITECH GmbH

TERASAKI ELECTRIC EUROPE LTD.
Pol.Ind.Coll de la Manya, C/Cal Ros dels Ocells 5
08403 Granollers, Barcelona, España
Tel. +34 93 879 60 50
Fax +34 93 870 39 05
email: terasaki@terasaki.es
Web: www.terasaki.es



900 60 50 70

proyectoselectricos@terasaki.es
ventas@terasaki.es
marketing@terasaki.es

