

# HENIKWON Technical Brochure

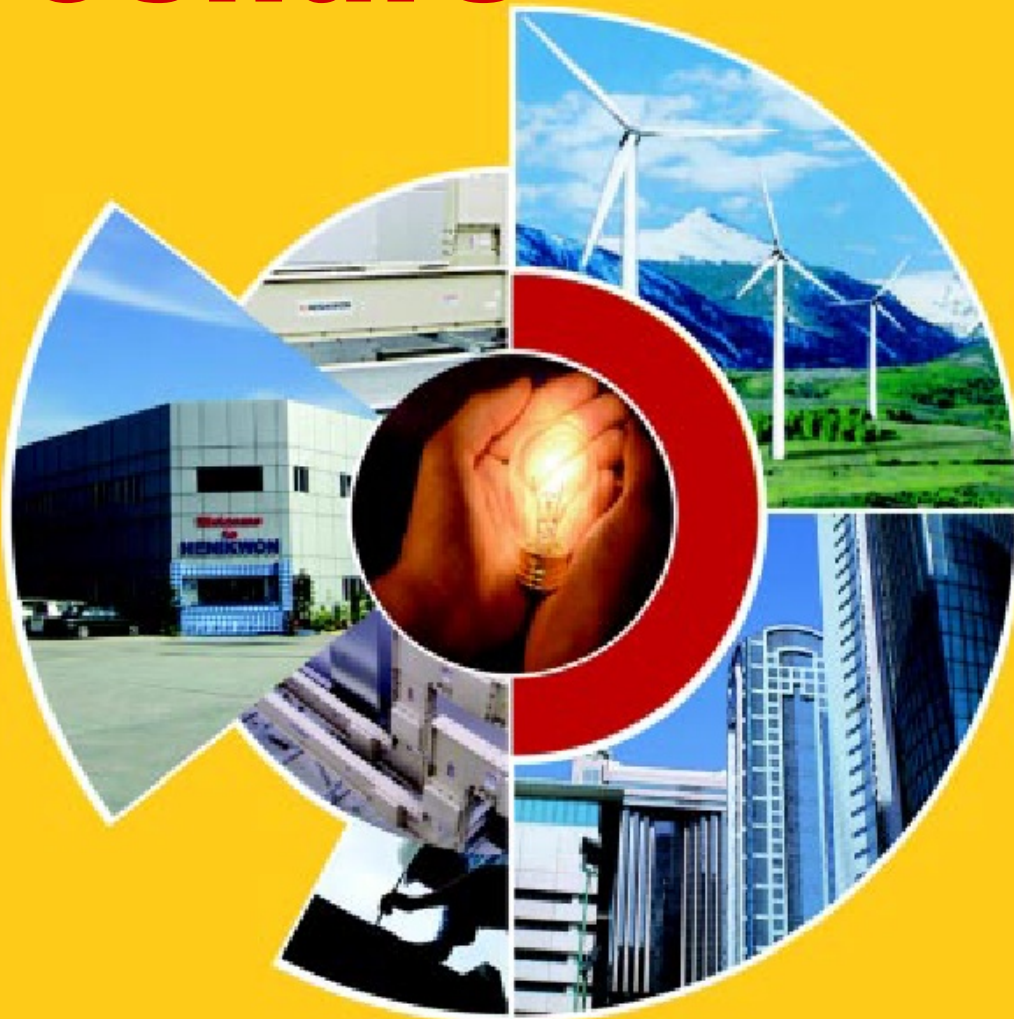

**HENIKWON**

ONLY ONE SCM BUSDUCT SYSTEM

Leading to better

**Power**

distribution

**SCM BUSDUCT SYSTEM**



# Values of HENIKWON

INNOVATION  
CHALLENGE  
TEAM WORK  
CUSTOMER FIRST

SPEED UP

SIMPLE &  
CONVENIENCE

VISIBLE  
MANAGEMENT

PRESENT  
POSITION

# Contents

<b>1. ABOUT HENIKWON</b>	2
<b>2. SCM BUSDUCT SYSTEM – LOW VOLTAGE</b>	
General Specification	6
Electrical Characteristics	8
Product Selection	12
Design Factors For Busduct Layout	24
Installation Manual	27
<b>3. HIGHBAR BUSDUCT SYSTEM – HIGH VOLTAGE</b>	
General Specification	31
Product Selection	32
<b>4. AIRBAR BUSDUCT SYSTEM</b>	
General Specification	34
Product Selection	35
Installation Manual	38
<b>5. IP STANDARDS</b>	39



# TOGETHER TODAY WE ARE GOING TO MAKE SUCCESSFUL HISTORY

## **1 WE HAVE THE POWER**

Henikwon Corporation is established in 1982, a progressive market leader in electrical equipment industry playing a pioneering role, producing high performance and quality product with excellent services to the customers. Our technology is enhancing customer's performances while lowering environment impact.

We constantly achieve a high level of quality in compliance to the international standards in products and management.

When you choose Henikwon Busduct system, we know you are partnering with a reliable supplier of Busduct system ideally configured for your application.

Whether you require Busduct system for reliable quality, prime or standby application, we can meet your needs with our range of quality products developed by highly skilled engineers and technicians coupled with excellent services provided by our reliable team.

To meet all your requirements for low, medium and high voltage Busduct systems, we rely on our expertise in power distribution, ranging from 100Amp to 6300Amp.

Our cycle of success thrives on our commitment, innovations, challenge, teamwork and "Customer First" motto.

This is what makes us and gives us an edge with a deep understanding of the market and an appreciation of our customers most critical needs. Worry no further, we're here to find the best solutions to make your life a better one!



HENIKWON is positioning itself as a global manufacturing leader in the busduct system industry by its earmarking product quality and good services. It has embarked on to establish and maintain a strong interface between the organization and its customers as a partnership. This will provide accurate feedback on all customer service issues and identify business solutions to continually improve service performance and responsiveness.

## **A World Leader in the Busduct System through Innovation**

1

HENIKWON's customer driven R&D develops tailor made solutions for specific market needs, making us the partner of choice and the leading busduct system manufacturer. With a resolution in energy where it gives the rapid widespread deployment of advanced, clean, and sustainable energy sources, we will try to be the integral part of the solution to the industrial needs.

## **The Future Energy Henikwon**



### 1 Quality, Reliability, Precision

Quality, reliability and precision are the hallmarks of our Henikwon philosophy. They represent concepts and values to which we are totally committed. In Henikwon, quality means that all our employees take personal responsibility for the company as a whole and in particular, for their own field of work. This individual commitment to perfection results in product superiority, which our products are ideally tailored to our customer's needs and fulfill market requirements. We ensure a high level of customer satisfaction. We familiarize ourselves with their needs, requirements and products as well as learn from past experiences of dealing with our customer in order to render our best services to them.

### Quality Is Our Philosophy

Responsibility and imaginations are part of our quality, which make our products reliable and our customer satisfied. Our employees are 100% committed to deliver defect-free products and excellent service through continuous improvements.

Our latest high-tech manufacturing process improves quality and productivity. Automation in our manufacturing workshops has led to a significant advancement in efficiency, productivity and quality.

All products undergo functional and power testing before dispatch. These make our smooth flow of organization operation possible in complying with ISO9001: 2000, OHSAS18001:2007, MS 1722 : 2005, and ISO14001: 2004.





Henikwon Busduct System is fully type tested through various international independent laboratories in world wide, proving its best quality product compliances to the international standards;

- IEC 60439 – 1 & 2: 2005
- IEC 62271 – 200: 2003
- IEC 60529: 2001 – 02
- IEC 60331: 2001 – 02
- BS EN 60439 – 1 & 2: 2000
- AS NZ 3439 – 2: 2002
- NEMA BU 1
- AS 3439 – 2 – 1994
- AS 60529 – 2004
- VDE 532
- JISC 8364
- CCC

## Endless R & D investments and International recognitions through tests

1

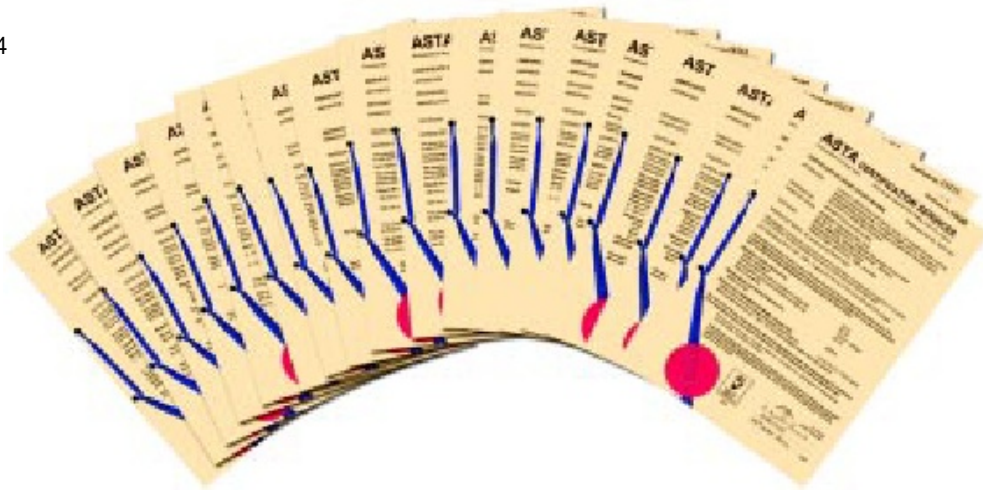

### GENERAL SPECIFICATION

#### Superior Compact & Sandwich Type Design

Henikwon SCM Busduct System is light weight, low impedance, non-ventilated, naturally cooled and totally enclosed for protection against mechanical damages and dust accumulation in compact and sandwich type.

Our design does not require fire stop or internal barriers in each busduct length/unit due to its compact & sandwich type construction.

Moreover, galvanized steel housing or extruded aluminum housing with epoxy compound powder coated by an automated electrostatic process enables to achieve fire resistance, and housing would give integral ground as standard requirement.

#### Busbar

99.9% copper busbar is tin coated with epoxy compound insulation. This is to prevent from water and moisture that can cause reduction in dielectric resistance, and its flame retardant ensures the safety. Likewise, aluminum busbar is silver coated at the joint parts for better conductivity.

#### Joints

To check for tightness without de-energizing the busduct system, the joints shall be of maintenance-free system with one-bolt type. The high strength bolt is insulated by a high quality insulation material for heat and impact forces.

For uniformed distribution of the clamping force over the joints, all bolted connections are equipped with Belleville washers.

The joint design shall permit safe practical testing of joints for tightness without de-energizing the busduct and it is possible to remove any one section in a run without disturbing the two adjacent busduct sections.

It shall have an adjustability of  $\pm 14\text{mm}$  for a precise alignment and to facilitate an easy field installation. The maintenance-free nut is provided where the outer head will be twisted off once it reaches  $1500\text{kg}\cdot\text{cm}$  which will act as lock nut.

#### Earth System

Henikwon SCM Busduct System is an integral housing ground system as per standards where the housing act as an earth conductor. The busduct housing is constructed to have positive electric continuity through housing faces. It is also available with internal ground, 200% neutral conductor, as per requirement.

Additional external earth tape can be fixed to the outer part of the housing as per requirement. However, it is contractor's scope of supply.

#### Plug-in Hole

A maximum five units of plug-in holes can be designed in 3000mm standard feeder unit on both sides and each plug-in hole shall have 500mm intervals. Plug-in hole is well designed to prevent improper installation of plug-in box.

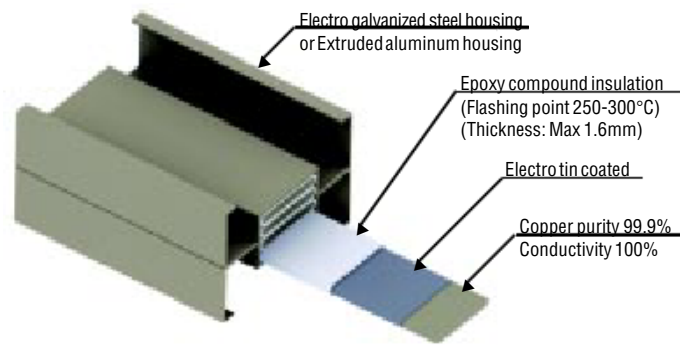

Copper Busduct System

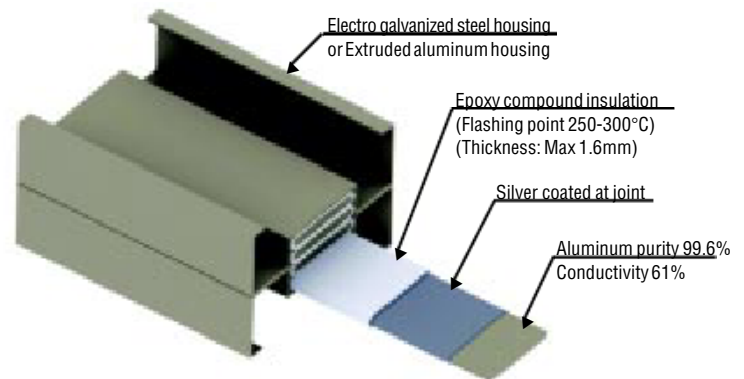

Aluminum Busduct System

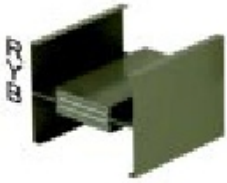

3 PHASE 3 WIRE  
WITH INTEGRAL GROUND

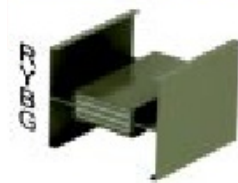

3 PHASE 3 WIRE  
WITH INTERNAL GROUND

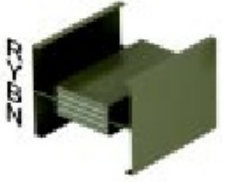

3 PHASE 4 WIRE  
WITH INTEGRAL GROUND AND 100% NEUTRAL

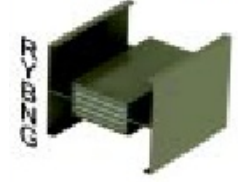

3 PHASE 4 WIRE  
WITH INTERNAL GROUND AND 100% NEUTRAL

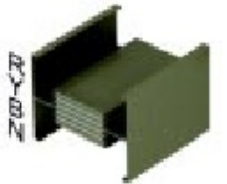

3 PHASE 5 WIRE  
WITH INTEGRAL GROUND AND 200% NEUTRAL

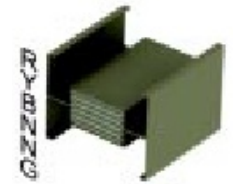

3 PHASE 5 WIRE  
WITH INTERNAL GROUND AND 200% NEUTRAL



2 PHASE 5 WIRE  
WITH 25% + 25% INTERNAL GROUND AND 100% NEUTRAL

### Plug-in Box Safety Devices

Plug-in box shall be mechanically interlocked with the busduct housing to prevent installation or removal of plug-in box while

the switch is in 'ON' position. It is equipped with an operating handle which will always remain in control of the switching mechanism.

Before the jaws make contact with the busbar, the plug-in box enclosure shall make positive ground connection to the busduct housing.

The plug-in box is also equipped with internal insulation barriers to prevent accidental contact of housing plate and conductors. To prevent the plug-in box cover from being opened while the switch is in 'ON' position, the covers of all plug-in boxes shall have 'releasable' type of interlocks. The plugs shall be provided with means of padlocking the switch in the 'OFF' position.

With live parts which are on the sideline of the protective device during time of wire pulling.

### Expansion Joints

Expansion joint shall be installed when necessary and it shall be capable of taking up all thermal expansions, assuming in full-load condition.

### Support of Busduct

Supporting interval for horizontal run shall not exceed 1.5 meters. Vertical riser of busduct shall be supported adequately with spring hangers at each floor. Immediate supports shall be provided if the floor to floor distance exceeds 4 meters.

### Ambient Temperature

Due to liberal cross section area of the conductors and superior housing design, Henikwon SCM Busduct Systems can be loaded at rated current at an ambient temperature of 50°C without derating (IEC standard requirement is 35°C).

### Short-time Current Capacity

The short-time current capacity of the busduct shall not be less than the value given as per the table on page 9.

### Impedance Value

The impedance of the busduct shall not exceed the value given as per the table on page 10.

### EMC Compatible

Henikwon SCM busduct system is tested EMC compatible.

### Application Data

- 1) Operating Voltage: 2,000 Volts
- 2) Withstand Voltage: 10,000 Volts
- 3) Class of Insulation and Insulation Material:  
Class F 155°C with epoxy compound insulation
- 4) System Configuration:  
3ø3W, 3ø3W+G, 3ø4W, 3ø4W+G, 3ø5W, 3ø5W+G
- 5) Degree of Protection: Indoor / Weather-proof – Min. IP54  
Outdoor – IP55~IP68, IP for Plug-in hole / Tap-off – IP20
- 6) Fire Resistant Busduct comply to IEC 60331 & BS 6387



Henikwon Busduct  
System in test chamber  
with burner



Henikwon Busduct  
System under ASTA  
Type Test

### ELECTRICAL CHARACTERISTICS

#### 1. DIMENSIONS

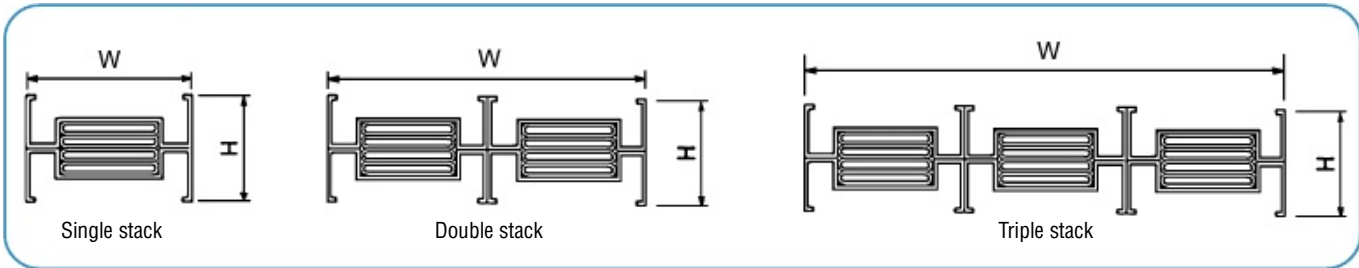

#### Copper Conductor

Ampere (A)	Conductor	Width	Dimension (mm)						Weight (kg/m)					
			Height						Indoor Busduct			Outdoor Busduct		
			Indoor Busduct			Outdoor Busduct			Indoor Busduct			Outdoor Busduct		
3W	4W	5W	3W	4W	5W	3W	4W	5W	3W	4W	5W	3W	4W	5W
400	4x40-1	115	100	120	140	170	190	210	11.0	13.2	15.5	15.5	17.8	20.0
630	6x50-1	125	100	120	140	170	190	210	15.2	18.8	22.3	19.7	23.3	26.9
800	6x55-1	130	100	120	140	170	190	210	16.1	20.0	23.9	20.7	24.5	28.4
1000	6x75-1	150	100	120	140	170	190	210	20.1	25.1	30.1	24.7	29.6	34.6
1250	6x100-1	175	100	120	140	170	190	210	25.0	31.4	37.8	29.5	35.9	42.3
1500	6x125-1	200	100	120	140	170	190	210	29.8	37.7	45.5	34.4	42.2	50.0
1600	6x150-1	225	100	120	140	170	190	210	34.7	44.0	53.2	39.3	48.5	57.7
2000	6x185-1	260	100	120	140	170	190	210	41.6	52.8	64.0	46.1	57.3	68.5
2500	6x240-1	315	100	120	140	170	190	210	52.4	66.7	81.0	56.9	71.2	85.5
3200	6x150-2	450	100	120	140	170	190	210	69.5	87.9	106.4	74.0	92.5	110.9
3500	6x175-2	500	100	120	140	170	190	210	79.3	100.6	121.8	83.8	105.1	126.4
4000	6x185-2	520	100	120	140	170	190	210	83.2	105.6	128.0	87.7	110.1	132.5
4500	6x220-2	590	100	120	140	170	190	210	96.9	123.2	149.6	101.4	127.8	154.1
5000	6x240-2	630	100	120	140	170	190	210	104.7	133.3	162.0	109.2	137.9	166.5
6300	6x185-3	780	100	120	140	170	190	210	124.8	158.4	192.0	129.3	162.9	196.5

#### Aluminum Conductor

Ampere (A)	Conductor	Width	Dimension (mm)						Weight (kg/m)					
			Height						Indoor Busduct			Outdoor Busduct		
			Indoor Busduct			Outdoor Busduct			Indoor Busduct			Outdoor Busduct		
3W	4W	5W	3W	4W	5W	3W	4W	5W	3W	4W	5W	3W	4W	5W
400	5x55-1	130	100	120	140	170	190	210	8.0	9.6	11.1	12.6	14.2	15.7
630	6x55-1	130	100	120	140	170	190	210	9.6	11.4	13.1	14.3	16.0	17.7
800	6x75-1	150	100	120	140	170	190	210	11.2	13.2	15.3	15.8	17.8	19.9
1000	6x100-1	175	100	120	140	170	190	210	13.1	15.6	18.1	17.7	20.2	22.7
1250	6x125-1	200	100	120	140	170	190	210	15.1	18.0	20.9	19.7	22.6	25.5
1500	6x175-1	250	100	120	140	170	190	210	19.0	22.7	26.5	23.6	27.3	31.1
1600	6x185-1	260	100	120	140	170	190	210	19.7	23.7	27.6	24.3	28.3	32.2
2000	6x240-1	315	100	120	140	170	190	210	24.0	28.9	33.7	28.6	33.5	38.3
2500	6x150-2	450	100	120	140	170	190	210	34.0	40.7	47.3	38.6	45.3	51.9
3200	6x185-2	520	100	120	140	170	190	210	39.5	47.3	55.2	44.1	51.9	59.8
3500	6x220-2	590	100	120	140	170	190	210	44.9	53.9	63.0	49.5	58.5	67.6
4000	6x240-2	630	100	120	140	170	190	210	48.0	57.7	67.5	52.6	62.3	72.1
4500	6x185-3	780	100	120	140	170	190	210	59.2	71.0	82.7	63.8	75.6	87.4
5000	6x240-3	945	100	120	140	170	190	210	72.0	86.6	101.2	76.6	91.2	105.8

### Outdoor Type Busduct

Full protection of IP55-68 busduct system is in special joint cover system to provide protection from water and dust.

Protection rating design will be based on the site condition.



2

## 2. HIGH SHORT CIRCUIT CAPACITY

The allowable short time current capacity of the standard SCM Busduct System is shown in the table below.

We design a busduct with a large capacity subject to requirement.

### Determining Conductor Size

Maximum permissible current carrying capacity and short circuit current are the aspects needed in selecting a conductor size. Short circuit current capacity can be determined by operating temperature, short circuit temperature and short circuit duration.

Ampere (A)	Short Circuit	
	(kA/1sec)	(kA/3sec)
400	28	20
630	55	39
800	55	39
1000	60	42
1250	70	49
1500	80	56
1600	90	63
2000	100	70
2500	130	91
3200	160	112
3500	160	112
4000	200	140
4500	240	168
5000	240	168
6300	240	168

### 3. IMPEDANCE

#### Copper Conductor

(Unit:  $10^{-5}\Omega/m$ )

Ampere (A)	Conductor (mm)	RDC	50Hz			60Hz		
			RAC	X	Z	RAC	X	Z
400	4x40-1	13.952	14.133	3.318	14.517	14.175	3.981	14.723
630	6x50-1	7.441	7.664	3.225	8.315	7.731	3.870	8.646
800	6x55-1	6.764	6.998	3.002	7.615	7.062	3.603	7.928
1000	6x75-1	4.961	5.214	2.354	5.721	5.278	2.825	5.986
1250	6x100-1	3.720	4.006	1.853	4.414	4.094	2.224	4.659
1500	6x125-1	2.976	3.291	1.527	3.628	3.370	1.833	3.836
1600	6x150-1	2.480	2.807	1.298	3.093	2.879	1.557	3.273
2000	6x185-1	2.011	2.342	1.071	2.575	2.405	1.285	2.727
2500	6x240-1	1.550	1.874	0.838	2.053	1.929	1.005	2.175
3200	6x150-2	1.240	1.404	0.667	1.554	1.439	0.801	1.647
3500	6x175-2	1.063	1.228	0.578	1.357	1.261	0.694	1.439
4000	6x185-2	1.006	1.171	0.549	1.293	1.203	0.658	1.371
4500	6x220-2	0.846	1.009	0.465	1.111	1.038	0.558	1.178
5000	6x240-2	0.775	0.937	0.428	1.030	0.965	0.513	1.093
6300	6x185-3	0.670	0.781	0.369	0.864	0.802	0.443	0.916

#### Aluminum Conductor

(Unit:  $10^{-5}\Omega/m$ )

Ampere (A)	Conductor (mm)	RDC	50Hz			60Hz		
			RAC	X	Z	RAC	X	Z
400	5x55-1	13.384	13.567	2.804	13.854	13.608	3.365	14.018
630	6x55-1	11.154	11.340	3.002	11.731	11.377	3.603	11.934
800	6x75-1	8.179	8.389	2.354	8.713	8.459	2.825	8.918
1000	6x100-1	6.134	6.377	1.853	6.641	6.438	2.224	6.811
1250	6x125-1	4.908	5.162	1.527	5.383	5.228	1.883	5.557
1500	6x175-1	3.505	3.800	1.127	3.964	3.884	1.353	4.113
1600	6x185-1	3.316	3.618	1.071	3.773	3.699	1.285	3.916
2000	6x240-1	2.556	2.878	0.838	2.998	2.949	1.005	3.116
2500	6x150-2	2.045	2.178	0.667	2.278	2.224	0.801	2.364
3200	6x185-2	1.658	1.809	0.549	1.890	1.850	0.658	1.964
3500	6x220-2	1.394	1.553	0.465	1.621	1.590	0.558	1.685
4000	6x240-2	1.278	1.439	0.428	1.501	1.475	0.513	1.562
4500	6x185-3	1.105	1.206	0.369	1.261	1.233	0.443	1.310
5000	6x240-3	0.852	0.959	0.288	1.001	0.983	0.345	1.042

### 4. VOLTAGE DROP

#### Voltage Drop: Line to Line in Copper Conductor

(Unit : Volt/100m)

Ampere (A)	Conductor (mm)	3Ø 50Hz Power Factor						3Ø 60Hz Power Factor					
		1.00	0.90	0.85	0.80	0.70	0.60	1.00	0.90	0.85	0.80	0.70	0.60
400	4x40-1	9.79	9.81	9.53	9.21	8.50	7.71	9.82	10.04	9.80	9.51	8.84	8.10
630	6x50-1	7.96	8.63	8.54	8.38	7.97	7.46	8.03	8.98	8.95	8.84	8.50	8.04
800	6x55-1	9.70	10.54	10.43	10.25	9.76	9.15	9.79	10.98	10.95	10.82	10.42	9.87
1000	6x75-1	9.03	9.91	9.82	9.67	9.23	8.68	9.14	10.36	10.35	10.25	9.89	9.40
1250	6x100-1	8.33	9.17	9.11	8.97	8.58	8.08	8.51	9.67	9.67	9.58	9.26	8.80
1500	6x125-1	8.55	9.42	9.36	9.22	8.82	8.30	8.76	9.96	9.95	9.86	9.53	9.06
1600	6x150-1	7.78	8.57	8.51	8.38	8.01	7.55	7.98	9.06	9.05	8.97	8.67	8.24
2000	6x185-1	8.11	8.92	8.85	8.72	8.33	7.84	8.33	9.44	9.43	9.34	9.01	8.56
2500	6x240-1	8.11	8.88	8.81	8.67	8.27	7.77	8.35	9.41	9.39	9.29	8.95	8.49
3200	6x150-2	7.78	8.62	8.56	8.44	8.09	7.63	7.98	9.11	9.12	9.04	8.75	8.34
3500	6x175-2	7.44	8.23	8.17	8.06	7.71	7.27	7.64	8.71	8.71	8.64	8.36	7.95
4000	6x185-2	8.11	8.96	8.90	8.77	8.40	7.91	8.33	9.49	9.49	9.40	9.09	8.65
4500	6x220-2	7.86	8.66	8.59	8.47	8.09	7.62	8.09	9.18	9.17	9.08	8.77	8.33
5000	6x240-2	8.11	8.92	8.85	8.72	8.33	7.83	8.36	9.46	9.44	9.35	9.02	8.57
6300	6x185-3	8.52	9.43	9.36	9.23	8.84	8.33	8.75	9.98	9.99	9.90	9.58	9.12

#### Voltage Drop: Line to Line in Aluminum Conductor

(Unit : Volt/100m)

Ampere (A)	Conductor (mm)	3Ø 50Hz Power Factor						3Ø 60Hz Power Factor					
		1.00	0.90	0.85	0.80	0.70	0.60	1.00	0.90	0.85	0.80	0.70	0.60
400	5x55-1	9.40	9.31	9.01	8.69	7.97	7.19	9.43	9.50	9.24	8.94	8.26	7.52
630	6x55-1	11.78	11.97	11.66	11.30	10.48	9.57	11.82	12.27	12.02	11.71	10.95	10.09
800	6x75-1	11.62	11.88	11.60	11.26	10.47	9.58	11.72	12.26	12.03	11.73	11.00	10.16
1000	6x100-1	11.05	11.34	11.08	10.76	10.02	9.19	11.15	11.71	11.51	11.23	10.56	9.77
1250	6x125-1	10.73	11.04	10.79	10.49	9.78	8.98	10.87	11.49	11.30	11.04	10.40	9.65
1500	6x175-1	9.87	10.16	9.93	9.65	9.00	8.27	10.09	10.61	10.43	10.18	9.57	8.87
1600	6x185-1	10.03	10.32	10.09	9.80	9.14	8.39	10.25	10.78	10.59	10.34	9.72	9.00
2000	6x240-1	9.97	10.24	10.00	9.72	9.05	8.30	10.22	10.71	10.52	10.26	9.64	8.91
2500	6x150-2	9.43	9.75	9.54	9.28	8.66	7.97	9.63	10.18	10.01	9.79	9.22	8.55
3200	6x185-2	10.03	10.35	10.13	9.85	9.19	8.45	10.25	10.82	10.64	10.39	9.78	9.07
3500	6x220-2	9.41	9.70	9.49	9.22	8.60	7.90	9.64	10.15	9.97	9.74	9.16	8.49
4000	6x240-2	9.97	10.27	10.04	9.75	9.10	8.35	10.22	10.75	10.56	10.31	9.69	8.97
4500	6x185-3	9.40	9.71	9.50	9.25	8.63	7.94	9.61	10.15	9.99	9.76	9.19	8.53
5000	6x240-3	8.31	8.56	8.37	8.14	7.59	6.98	8.51	8.96	8.81	8.60	8.09	7.50

#### Voltage Drop Calculation Formulas

$$\Delta V = \sqrt{3} \cdot I (R \cos\theta + X \sin\theta)$$

where  $\Delta V$ : Line-to-line voltage drop

$I$ : Load Current

$\cos\theta$ : Load power factor

$$\sin\theta = \sqrt{1 - \cos^2\theta}$$

$R$ : AC resistance at load current ( $\Omega/m$ )

$$R = R_{95} \times \frac{1 + \alpha (55 \times (I/I_0)^2 + 20)}{1 + 75\alpha}$$

$R_{95}$ : AC resistance at rated current ( $I_0$ ) ( $\Omega/m$ )  
(Shown in the above table)

$\alpha$ : Temperature coefficient of conductor at 20°C  
 $3.93 \times 10^{-3}$  (copper),  $4.03 \times 10^{-3}$  (aluminum)

$I_0$ : Rated Current

$X$ : Reactance (shown in the above table) ( $\Omega/m$ )

Note: It is not applicable to single phase & DC busduct.

### PRODUCT SELECTION

#### FEEDER



- Standard length: 3000mm.
- Min. length: 500mm.

- Standard length: 3000mm.
- Dimensions are shown as below:  
 $L$  = Lengths of straight plug-in busduct unit  
 $a_1$  = Length between the plug-in box cable lead-out side and the joint point  
 $a_2$  = Length of plug-in box  
 $a_3$  = Length between the end of plug-in box and the joint point

- Minimum length (L) is determined by the number of plug-in box to be installed. E.g.

Plug-in box :

Plug-in busduct for mounting MCCB 800AF

$a_1 = 180\text{mm}$ ,  $a_2 = 540\text{mm}$ ,  $a_3 = 180\text{mm}$

In the above case, the unit length (L) is 900mm.

- Two plug-in holes can be provided on top and bottom side of the busduct.
- The hole position are determined by the space of the plug-in boxes and the length between the boxes and joint points.
- A branch exceeding 500A belongs to tap-off box type. Standard dimensions of Plug-in Busduct (Copper /Aluminum)

#### PLUG-IN FEEDER

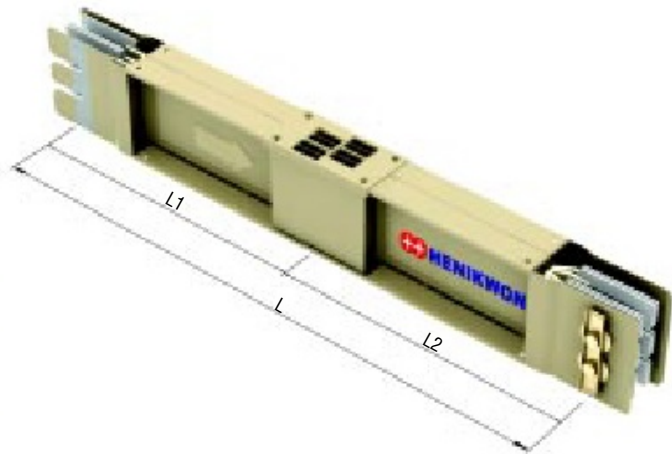

Conductor	(mm)	(mm)	Hole to Hole (mm)	Hole Qty
Copper/Aluminum	1500	1500	575	1

#### TAP-OFF FEEDER

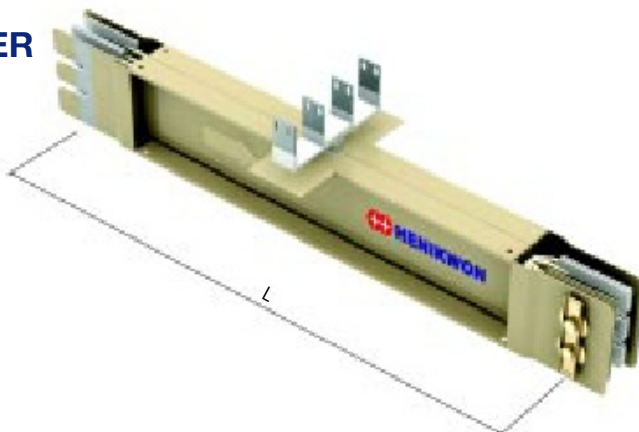

- Standard length: 3000mm.
- Min. length: 1200mm.
- Max. number of tap-off: 3 tap-offs in 3000mm.
- A branch of 500A & above belongs to a tap-off type.

**VERTICAL ELBOW**

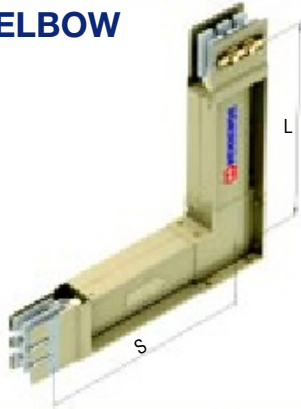

Ampere (A)	Standard (mm) S x L	Minimum (mm) S x L
400	500 x 500	325 x 325
630	500 x 500	330 x 330
800	500 x 500	330 x 330
1000	500 x 500	340 x 340
1250	500 x 500	353 x 353
1500	500 x 500	365 x 365
1600	500 x 500	378 x 378
2000	500 x 500	395 x 395
2500	500 x 500	423 X 423
3200	500 x 500	490 x 490
3500	700 x 700	515 x 515
4000	700 x 700	525 x 525
4500	700 x 700	580 x 580
5000	700 x 700	580 x 580
6300	700 x 700	670 x 670

**HORIZONTAL ELBOW**

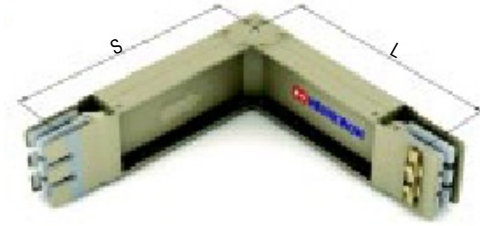

Ampere (A)	Standard (mm) S x L	Minimum (mm) S x L
400	500 x 500	300 x 300
630	500 x 500	300 x 300
800	500 x 500	300 x 300
1000	500 x 500	300 x 300
1250	500 x 500	300 x 300
1500	500 x 500	300 x 300
1600	500 x 500	300 x 300
2000	500 x 500	300 x 300
2500	500 x 500	300 x 300
3200	500 x 500	300 x 300
3500	500 x 500	300 x 300
4000	500 x 500	300 x 300
4500	500 x 500	300 x 300
5000	500 x 500	300 x 300
6300	500 x 500	300 x 300

2

**VERTICAL TEE ELBOW**

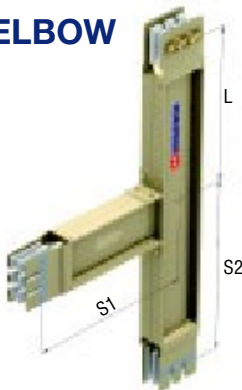

Ampere (A)	Standard (mm) S x L1 x L2	Minimum (mm) S x L1 x L2
400	500 x 500 x500	293 x 293 x 293
630	500 x 500 x500	300 x 300 x 300
800	500 x 500 x500	300 x 300 x 300
1000	500 x 500 x500	310 x 310 x 310
1250	500 x 500 x500	323 x 323 x 323
1500	500 x 500 x500	335 x 335 x 335
1600	500 x 500 x500	348 x 348 x 348
2000	500 x 500 x500	365 x 365 x 365
2500	500 x 500 x500	393 x 393 x 393
3200	500 x 500 x500	460 x 460 x 460
3500	750 x 750 x 750	485 x 485 x 485
4000	750 x 750 x 750	530 x 530 x 530
4500	750 x 750 x 750	530 x 530 x 530
5000	750 x 750 x 750	550 x 550 x 550
6300	750 x 750 x 750	670 x 670 x 670

**HORIZONTAL TEE ELBOW**

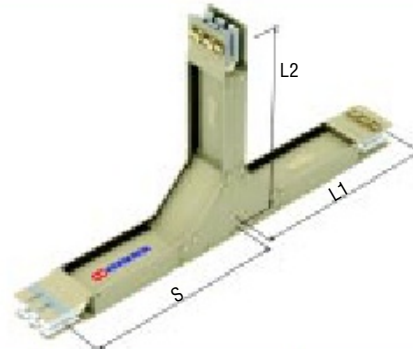

Ampere (A)	Standard (mm) S x L1 x L2	Minimum (mm) S x L1 x L2
400	500 x 500 x 500	300 x 210 x 300
630	500 x 500 x 500	300 x 210 x 300
800	500 x 500 x 500	300 x 210 x 300
1000	500 x 500 x 500	300 x 210 x 300
1250	500 x 500 x 500	300 x 210 x 300
1500	500 x 500 x 500	300 x 210 x 300
1600	500 x 500 x 500	300 x 210 x 300
2000	500 x 500 x 500	300 x 210 x 300
2500	500 x 500 x 500	300 x 210 x 300
3200	500 x 500 x 500	300 x 210 x 300
3500	500 x 500 x 500	300 x 210 x 300
4000	500 x 500 x 500	300 x 210 x 300
4500	500 x 500 x 500	300 x 210 x 300
5000	500 x 500 x 500	300 x 210 x 300
6300	500 x 500 x 500	300 x 210 x 300

### VERTICAL OFFSET ELBOW

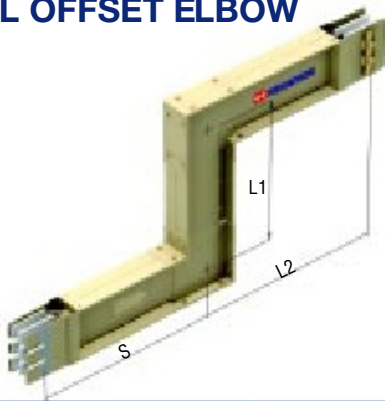

Ampere (A)	Standard (mm) S x L1 x L2	Minimum (mm) S x L1 x L2
400	500 x 500 x 500	323 X 260 X 323
630	500 x 500 x 500	300 X 275 X 330
800	500 x 500 x 500	330 X 275 X 330
1000	500 x 500 x 500	340 X 295 X 340
1250	500 x 500 x 500	353 X 320 X 353
1500	500 x 500 x 500	365 X 345 X 365
1600	500 x 500 x 500	378 X 370 X 378
2000	500 x 500 x 500	395 X 405 X 395
2500	500 x 500 x 500	423 X 460 X 423
3200	500 x 500 x 500	490 x 370 x 490
3500	750 x 750 x 750	515 x 395 x 515
4000	750 x 750 x 750	525 x 405 x 525
4500	750 x 750 x 750	560 x 440 x 560
5000	750 x 750 x 750	580 x 460 x 580
6300	750 x 750 x 750	670 x 450 x 670

### HORIZONTAL OFFSET ELBOW

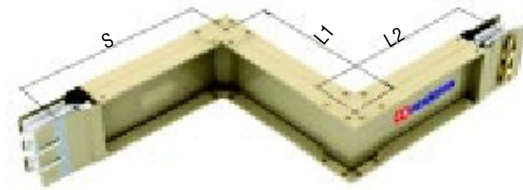

Ampere (A)	Standard (mm) S x L1 x L2	Minimum (mm) S x L1 x L2
400	500 x 500 x 500	300 x 210 x 300
630	500 x 500 x 500	300 x 210 x 300
800	500 x 500 x 500	300 x 210 x 300
1000	500 x 500 x 500	300 x 210 x 300
1250	500 x 500 x 500	300 x 210 x 300
1500	500 x 500 x 500	300 x 210 x 300
1600	500 x 500 x 500	300 x 210 x 300
2000	500 x 500 x 500	300 x 210 x 300
2500	500 x 500 x 500	300 x 210 x 300
3200	500 x 500 x 500	300 x 210 x 300
3500	500 x 500 x 500	300 x 210 x 300
4000	500 x 500 x 500	300 x 210 x 300
4500	500 x 500 x 500	300 x 210 x 300
5000	500 x 500 x 500	300 x 210 x 300
6300	500 x 500 x 500	300 x 210 x 300

### VERTICAL CROSS ELBOW

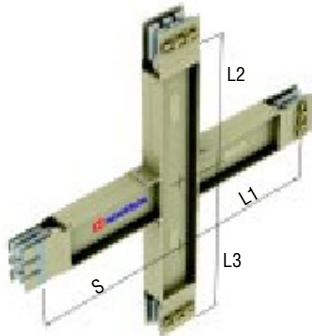

Ampere (A)	Standard (mm) S x L1 x L2 x L3	Minimum (mm) S x L1 x L2 x L3
400	500 x 500 x 500 x 500	293 x 293 x 293 x 293
630	500 x 500 x 500 x 500	300 x 300 x 300 x 300
800	500 x 500 x 500 x 500	300 x 300 x 300 x 300
1000	500 x 500 x 500 x 500	310 x 310 x 310 x 310
1250	500 x 500 x 500 x 500	323 x 323 x 323 x 323
1500	500 x 500 x 500 x 500	335 x 335 x 335 x 335
1600	500 x 500 x 500 x 500	348 x 348 x 348 x 348
2000	500 x 500 x 500 x 500	365 x 365 x 365 x 365
2500	500 x 500 x 500 x 500	393 x 393 x 393 x 393
3200	500 x 500 x 500 x 500	460 x 460 x 460 x 460
3500	750 x 750 x 750 x 750	485 x 485 x 485 x 485
4000	750 x 750 x 750 x 750	530 x 530 x 530 x 530
4500	750 x 750 x 750 x 750	530 x 530 x 530 x 530
5000	750 x 750 x 750 x 750	550 x 550 x 550 x 550
6300	750 x 750 x 750 x 750	670 x 670 x 670 x 670

### HORIZONTAL CROSS ELBOW

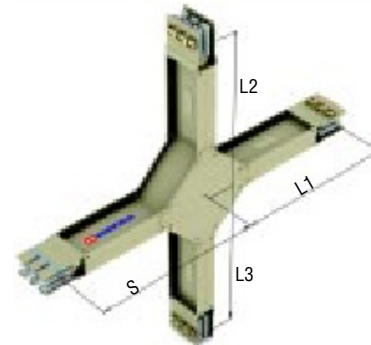

Ampere (A)	Standard (mm) S x L1 x L2 x L3	Minimum (mm) S x L1 x L2 x L3
400	500 x 500 x 500 x 500	350 x 350 x 350 x 350
630	500 x 500 x 500 x 500	360 x 360 x 360 x 360
800	500 x 500 x 500 x 500	360 x 360 x 360 x 360
1000	500 x 500 x 500 x 500	380 x 380 x 380 x 380
1250	500 x 500 x 500 x 500	400 x 400 x 400 x 400
1500	500 x 500 x 500 x 500	430 x 430 x 430 x 430
1600	600 x 600 x 600 x 600	460 x 460 x 460 x 460
2000	600 x 600 x 600 x 600	500 x 500 x 500 x 500
2500	600 x 600 x 600 x 600	560 x 560 x 560 x 560
3200	600 x 600 x 600 x 600	460 x 460 x 460 x 460
3500	600 x 600 x 600 x 600	490 x 490 x 490 x 490
4000	600 x 600 x 600 x 600	560 x 560 x 560 x 560
4500	600 x 600 x 600 x 600	530 x 530 x 530 x 530
5000	600 x 600 x 600 x 600	560 x 560 x 560 x 560
6300	600 x 600 x 600 x 600	500 x 500 x 500 x 500

### COMBINATION ELBOW

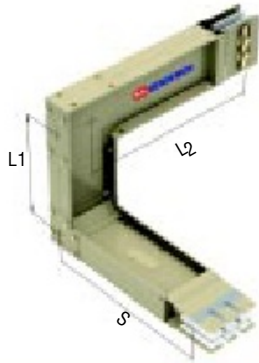

Ampere (A)	Standard (mm) S x L1 x L2	Minimum (mm) S x L1 x L2
400	500 x 500 x 500	300 x 233 x 323
630	500 x 500 x 500	300 x 240 x 330
800	500 x 500 x 500	300 x 240 x 330
1000	500 x 500 x 500	300 x 250 x 340
1250	500 x 500 x 500	300 x 263 x 353
1500	500 x 500 x 500	300 x 275 x 365
1600	500 x 500 x 500	300 x 288 x 378
2000	500 x 500 x 500	300 x 305 x 395
2500	500 x 500 x 500	300 x 333 x 423
3200	500 x 500 x 500	300 x 400 x 490
3500	700 x 700 x 700	300 x 425 x 515
4000	700 x 700 x 700	300 x 435 x 525
4500	700 x 700 x 700	300 x 470 x 560
5000	700 x 700 x 700	300 x 490 x 580
6300	700 x 700 x 700	300 x 580 x 670

### FEEDER WITH FLANGED END

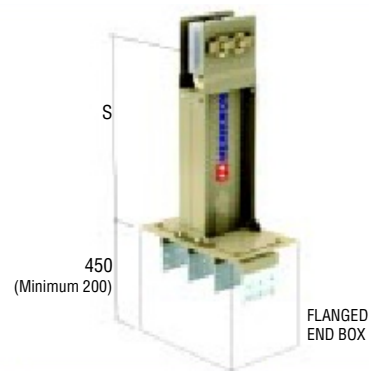

Ampere (A)	Standard (mm) S	Minimum (mm) S
400	500	250
630	500	250
800	500	250
1000	500	250
1250	500	250
1500	500	250
1600	500	250
2000	500	250
2500	500	250
3200	500	250
3500	500	250
4000	500	250
4500	500	250
5000	500	250
6300	500	250

### VERTICAL ELBOW WITH FLANGED END

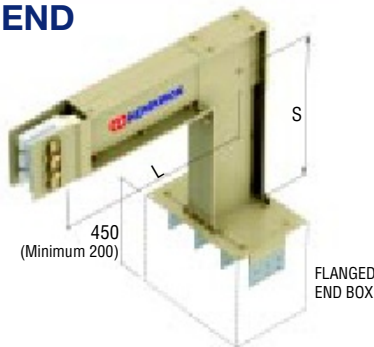

Ampere (A)	Standard (mm) S x L	Minimum (mm) S x L
400	500 x 500	178 x 323
630	500 x 500	185 x 330
800	500 x 500	185 x 330
1000	500 x 500	195 x 340
1250	500 x 500	208 x 353
1500	500 x 500	220 x 365
1600	500 x 500	233 x 378
2000	500 x 500	278 x 423
2500	500 x 500	320 x 465
3200	500 x 500	345 x 490
3500	700 x 700	370 x 515
4000	700 x 700	378 x 525
4500	700 x 700	415 x 560
5000	700 x 700	435 x 580
6300	700 x 700	520 x 670

### HORIZONTAL ELBOW WITH FLANGED END

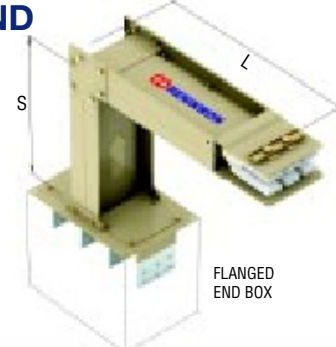

Ampere (A)	Standard (mm) S x L	Minimum (mm) S x L
400	500 x 500	180 x 300
630	500 x 500	180 x 300
800	500 x 500	180 x 300
1000	500 x 500	180 x 300
1250	500 x 500	180 x 300
1500	500 x 500	180 x 300
1600	500 x 500	180 x 300
2000	500 x 500	180 x 300
2500	500 x 500	180 x 300
3200	500 x 500	180 x 300
3500	500 x 500	180 x 300
4000	500 x 500	180 x 300
4500	500 x 500	180 x 300
5000	500 x 500	180 x 300
6300	500 x 500	180 x 300

### REDUCER

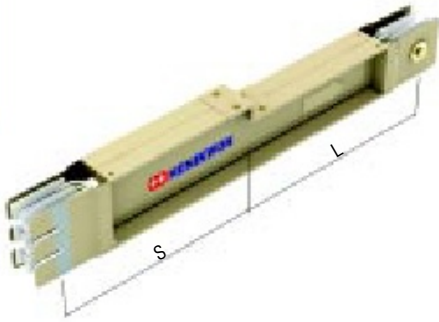

Ampere (A)	Standard (mm) S x L	Minimum (mm) S x L
400	500 x 500	300 x 300
630	500 x 500	300 x 300
800	500 x 500	300 x 300
1000	500 x 500	300 x 300
1250	500 x 500	300 x 300
1500	500 x 500	300 x 300
1600	500 x 500	300 x 300
2000	500 x 500	300 x 300
2500	700 x 700	450 x 450
3200	700 x 700	450 x 450
3500	700 x 700	450 x 450
4000	700 x 700	450 x 450
4500	700 x 700	450 x 450
5000	700 x 700	450 x 450
6300	700 x 700	450 x 450

### REDUCER WITH CIRCUIT BREAKER

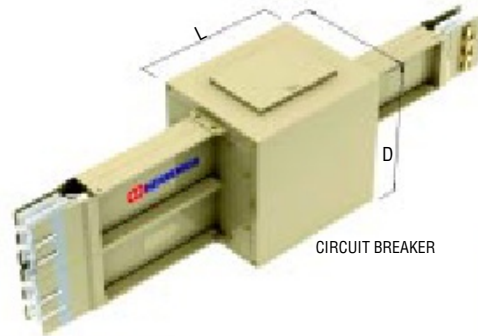

Ampere (A)	Minimum (mm) W x L x D
400	450 x 1180 x 250
630	450 x 1180 x 250
800	450 x 1180 x 250
1000	450 x 1340 x 270
1250	450 x 1340 x 295
1500	450 x 1365 x 320
1600	450 x 1365 x 345
2000	450 x 1425 x 380
2500	540 x 1425 x 520
3200	540 x 1500 x 570
3500	Dimension is subject to different circuit breaker
4000	
4500	
5000	
6300	

### EXPANSION JOINT

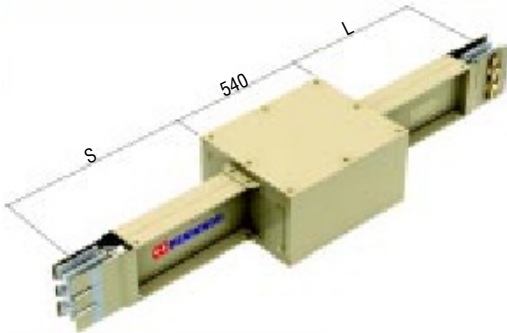

Ampere (A)	Standard (mm) S x L	Minimum (mm) S x L
400	500 x 500	300 x 300
630	500 x 500	300 x 300
800	500 x 500	300 x 300
1000	500 x 500	300 x 300
1250	500 x 500	300 x 300
1500	500 x 500	300 x 300
1600	500 x 500	300 x 300
2000	500 x 500	300 x 300
2500	500 x 500	300 x 300
3200	500 x 500	300 x 300
3500	500 x 500	300 x 300
4000	500 x 500	300 x 300
4500	500 x 500	300 x 300
5000	500 x 500	300 x 300
6300	500 x 500	300 x 300

### NECESSITY OF EXPANSION

The busduct expands and contracts due to the heat by current loading and the ambient temperature. The elongation of the busduct is approximately  $1.8 \times 10^{-2} \text{mm/m}^\circ\text{C}$ . For example, when the ambient temperature is  $30^\circ\text{C}$  and the temperature rise of busduct is  $40^\circ\text{C}$ , we have the below result of elongation for the busduct is as follows.

$$\blacktriangleright 1.8 \times 10^{-2} \times (30 + 40) = 1.26 \text{mm/m}$$

Moreover, there is a substance in respect to the busduct elongation by temperature rise, where the difference in the elongation between the conductor and the housing will result from a difference in their coefficients of expansion and temperature.

*\* This fitting is designed to absorb 25mm longitudinal expansion.*

### FLANGED END

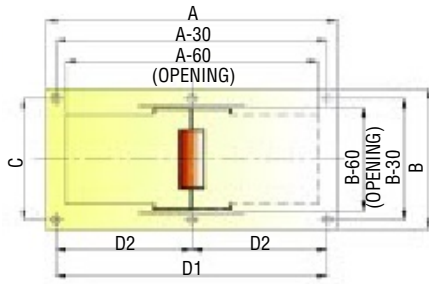

Figure 1

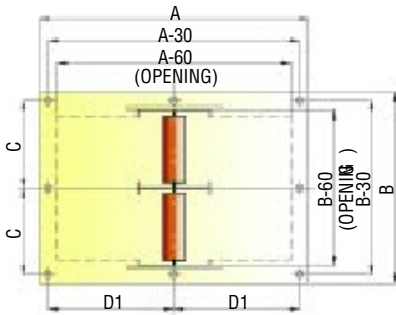

Figure 2

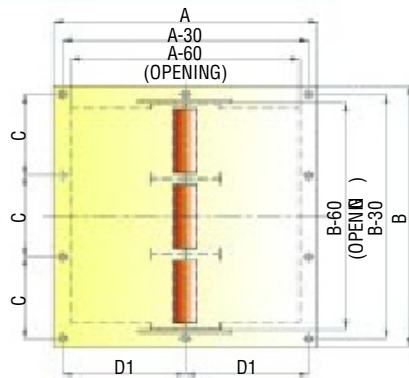
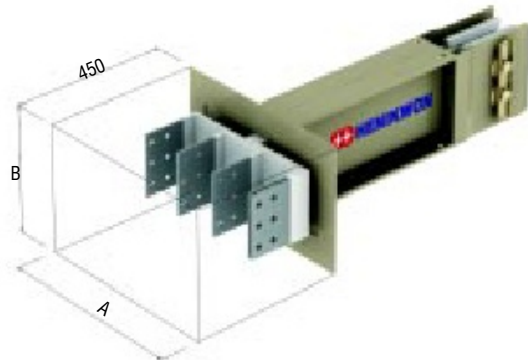
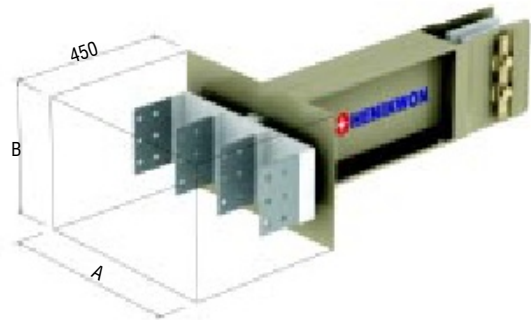
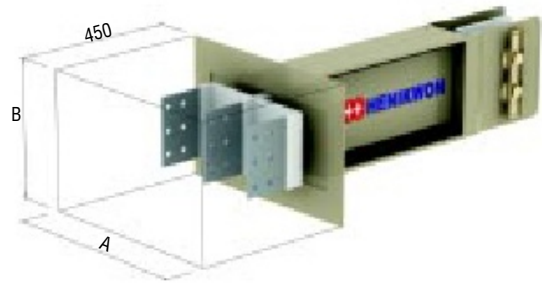

Figure 3

### FLANGED END BOX



2

Ampere (A)		Fig.	3W (mm)					4W (mm)					5W (mm)				
Copper	Aluminum		A	B	C	D1	D2	A	B	C	D1	D2	A	B	C	D1	D2
400	-	1	350	175	145	320	-	450	175	145	-	210	540	175	145	-	255
630	400	1	350	190	160	320	-	450	190	160	-	210	540	190	160	-	255
800	630	1	350	190	160	320	-	450	190	160	-	210	540	190	160	-	255
1000	800	1	350	210	180	320	-	450	210	180	-	210	540	210	180	-	255
1250	1000	1	350	235	205	320	-	450	235	205	-	210	540	235	205	-	255
1500	1250	1	350	260	230	320	-	450	260	230	-	210	540	260	230	-	255
1600	-	1	350	285	255	320	-	450	285	255	-	210	540	285	255	-	255
-	1500	1	350	310	280	320	-	450	310	280	-	210	540	310	280	-	255
2000	1600	1	350	320	290	320	-	450	320	290	-	210	540	320	290	-	255
2500	2000	1	350	375	345	320	-	450	375	345	-	210	540	375	345	-	255
3200	2500	2	410	510	240	190	-	540	510	240	255	-	540	510	240	255	-
3500	-	2	410	560	265	190	-	540	560	265	255	-	540	560	265	255	-
4000	3200	2	410	580	275	190	-	540	580	275	255	-	540	580	275	255	-
4500	3500	2	410	670	320	190	-	540	670	320	255	-	540	670	320	255	-
5000	4000	2	410	690	330	190	-	540	690	330	255	-	540	690	330	255	-
6300	4500	3	410	840	270	190	-	540	840	270	255	-	540	840	270	255	-
-	5000	3	410	1005	325	190	-	540	1005	325	255	-	540	1005	325	255	-

### DETAIL OF END TERMINAL

#### FLANGED END Integral Ground

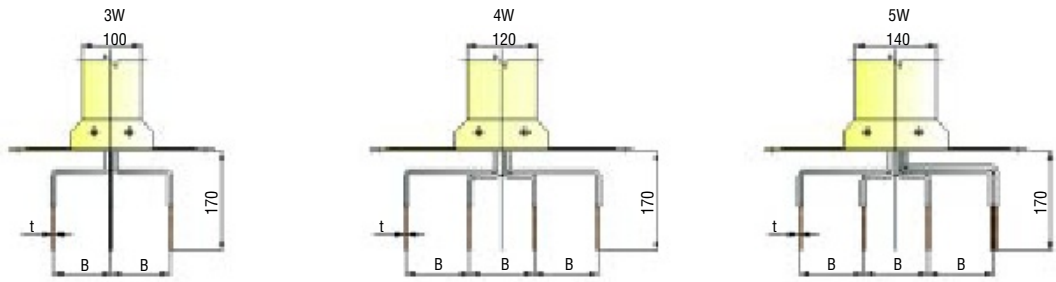

#### FLANGED END Internal Ground

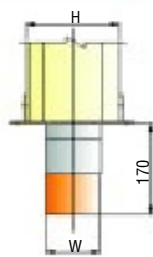
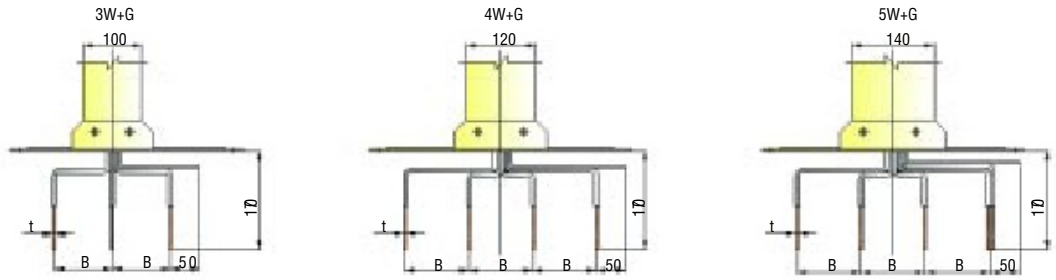

Figure 1.1

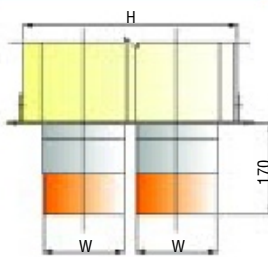

Figure 1.2

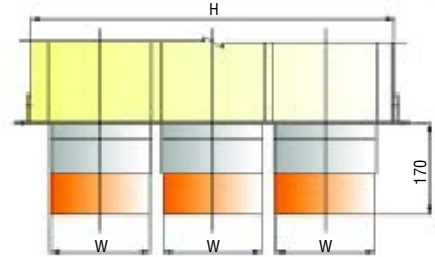
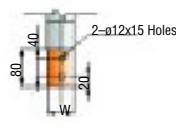
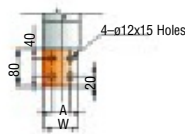

Figure 1.3

#### Bus bar hole pattern



Bar Width: 40-55mm  
Figure 1.4



Bar Width: 75-100mm  
Figure 1.5

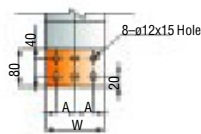

Bar Width: 125-150mm  
Figure 1.6

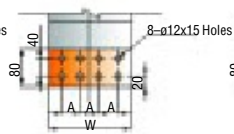

Bar Width: 175-185mm  
Figure 1.7

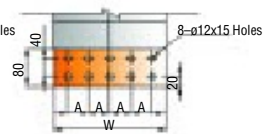

Bar Width: 220-240mm  
Figure 1.8

Ampere (A)		Fig.	Dimension (mm)					
Copper	Aluminum		Thickness	W	A	B (3W)	B (4W/5W)	H
400	-	1.1 and 1.4	4	40	-	100	110	175
630	400	1.1 and 1.4	6	55	-	100	110	190
800	630	1.1 and 1.4	6	55	-	100	110	190
1000	800	1.1 and 1.5	6	75	40	100	110	210
1250	1000	1.1 and 1.5	6	100	50	100	110	235
1500	1250	1.1 and 1.6	6	125	40	100	110	260
1600	-	1.1 and 1.6	6	150	50	100	110	285
-	1500	1.1 and 1.7	6	175	40	100	110	310
2000	1600	1.1 and 1.7	6	185	45	100	110	320
2500	2000	1.1 and 1.8	6	240	45	100	110	375
3200	2500	1.2 and 1.6	6	150	50	130	130	510
3500	-	1.2 and 1.7	6	175	40	130	130	560
4000	3200	1.2 and 1.7	6	185	45	130	130	580
4500	3500	1.2 and 1.8	6	220	45	130	130	670
5000	4000	1.2 and 1.8	6	240	45	130	130	690
6300	4500	1.3 and 1.7	6	185	45	130	130	840
-	5000	1.3 and 1.8	6	240	45	130	130	1005

**HORIZONTAL HANGER**

**Edgewise Installation**

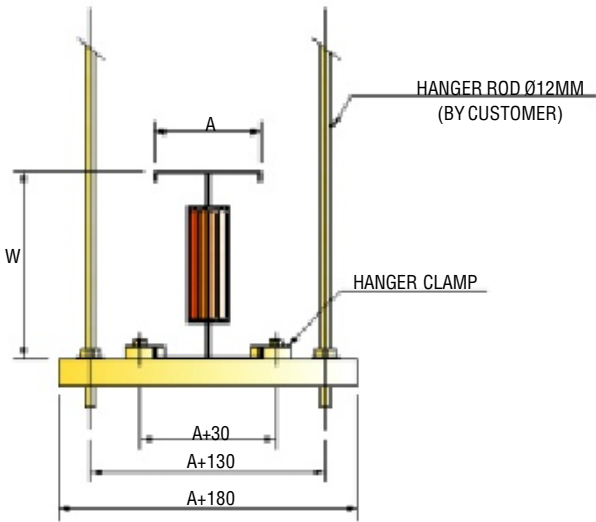

**Flatwise Installation**

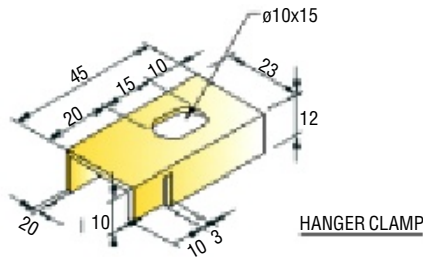
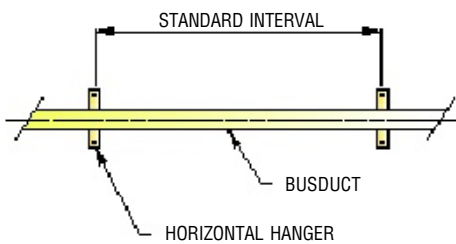
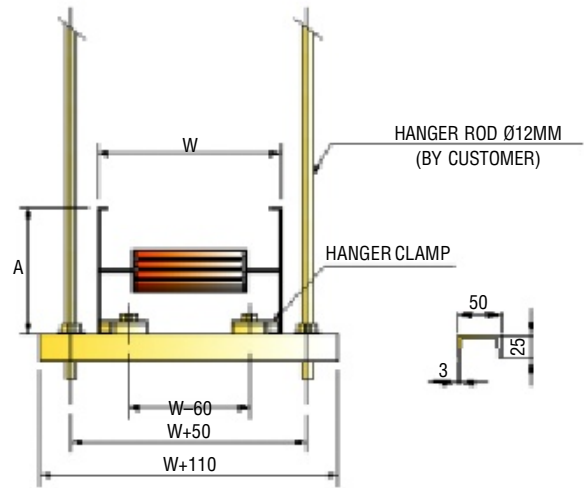

2

Ampere (A)		Stack	Dimension (mm)			
Copper	Aluminum		W	A		
				3W	4W	5W
400	-	1	115	100	120	140
630	400	1	125	100	120	140
800	630	1	130	100	120	140
1000	800	1	150	100	120	140
1250	1000	1	175	100	120	140
1500	1250	1	200	100	120	140
1600	-	1	225	100	120	140
-	1500	1	250	100	120	140
2000	1600	1	260	100	120	140
2500	2000	1	315	100	120	140
3200	2500	2	450	100	120	140
3500	-	2	500	100	120	140
4000	3200	2	520	100	120	140
4500	3500	2	590	100	120	140
5000	4000	2	630	100	120	140
6300	4500	3	780	100	120	140
-	5000	3	945	100	120	140

### VERTICAL FIX HANGER

### VERTICAL SPRING HANGER

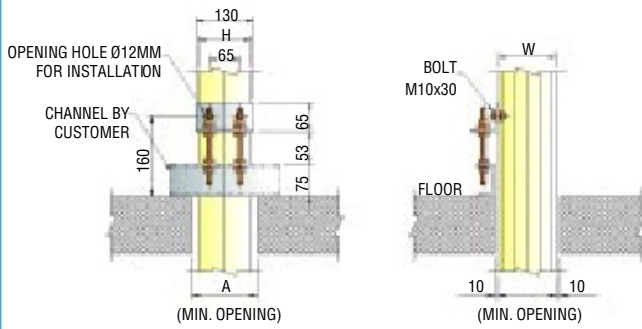

Figure 1.1

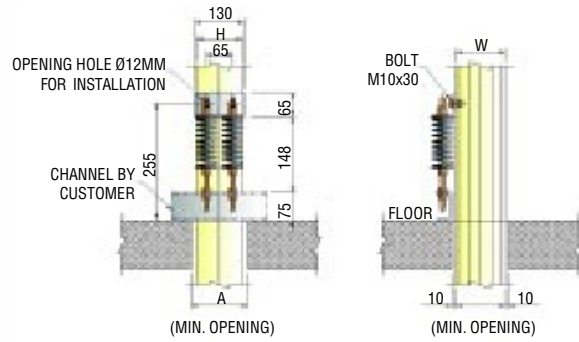

Figure 1.2

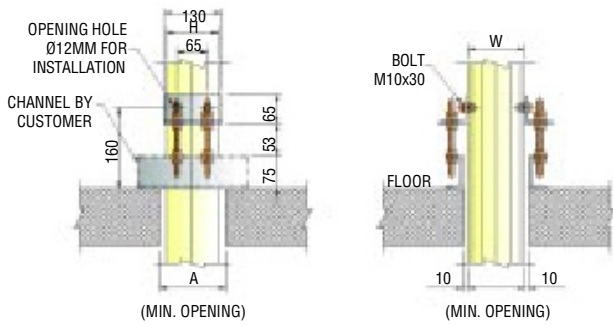

Figure 2.1

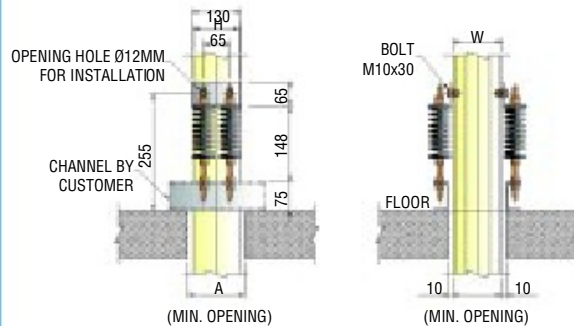

Figure 2.2

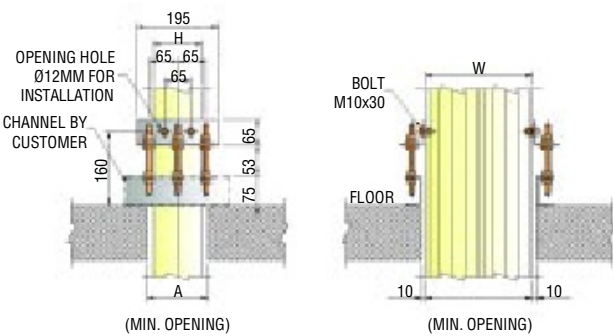

Figure 3.1

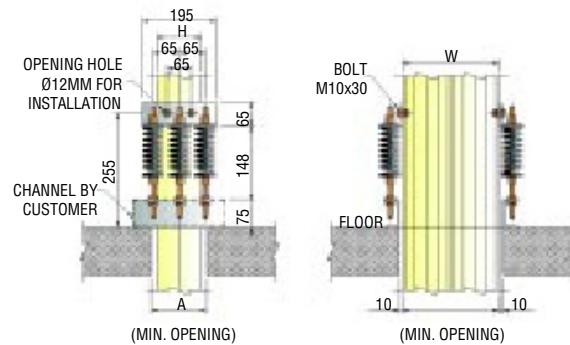

Figure 3.2

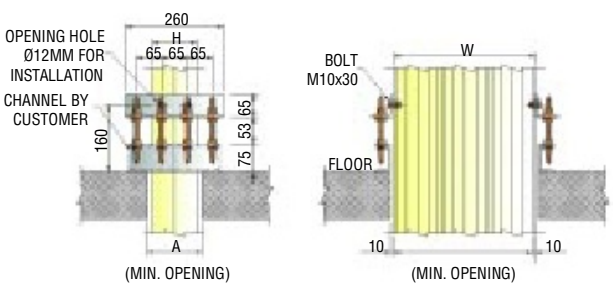

Figure 4.1

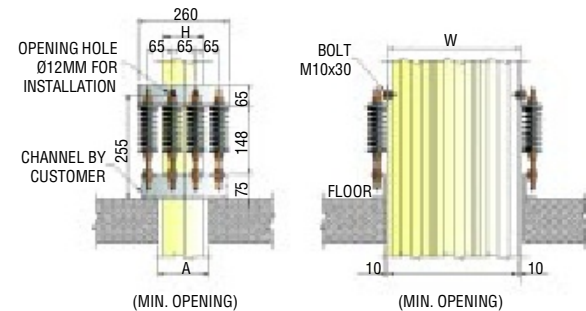

Figure 4.2

Ampere (A)		Fig.	Dimension (mm)						
Copper	Aluminum		W	H			A		
				3W	4W	5W	3W	4W	5W
400	-		115	100	120	140	130	150	170
630	-	1.1	125	100	120	140	130	150	170
800	630	1.2	130	100	120	140	130	150	170
1000	800		150	100	120	140	130	150	170
1200	1000		175	100	120	140	130	150	170
1500	1200		200	100	120	140	130	150	170
1600	-	2.1	225	100	120	140	130	150	170
-	1500	2.2	250	100	120	140	130	150	170
2000	1600		260	100	120	140	130	150	170

Ampere (A)		Fig.	Dimension (mm)						
Copper	Aluminum		W	H			A		
				3W	4W	5W	3W	4W	5W
2500	2000		315	100	120	140	130	150	170
3200	2500		450	100	120	140	130	150	170
3500	-		500	100	120	140	130	150	170
4000	3000	3.1	520	100	120	140	130	150	170
4500	3500	3.2	590	100	120	140	130	150	170
5000	4000		630	100	120	140	130	150	170
6300	4500	4.1	780	100	120	140	130	150	170
-	5000	4.2	945	100	120	140	130	150	170

\* Vertical spring hanger is installed to support busduct in each floor. When the height between the stories exceeds 4meters, a middle support is required.

### FLEXIBLE CONDUCTOR

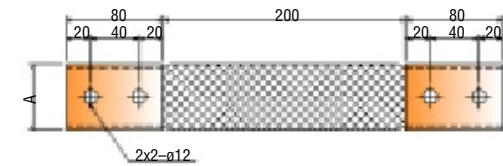

Figure 1

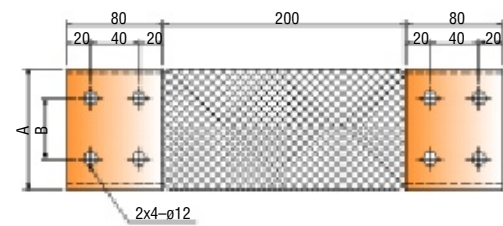

Figure 2

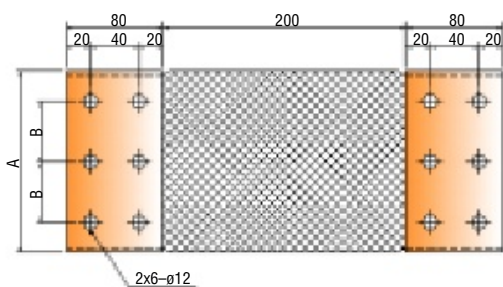

Figure 3

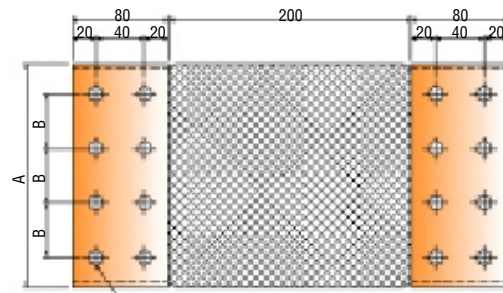

Figure 4

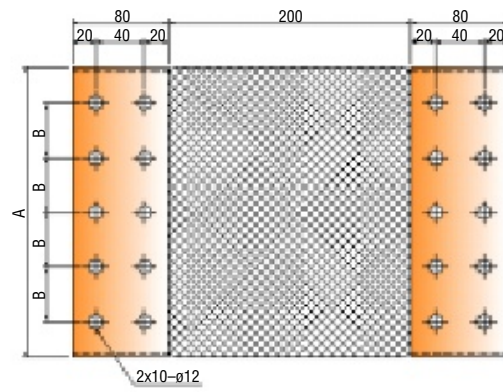
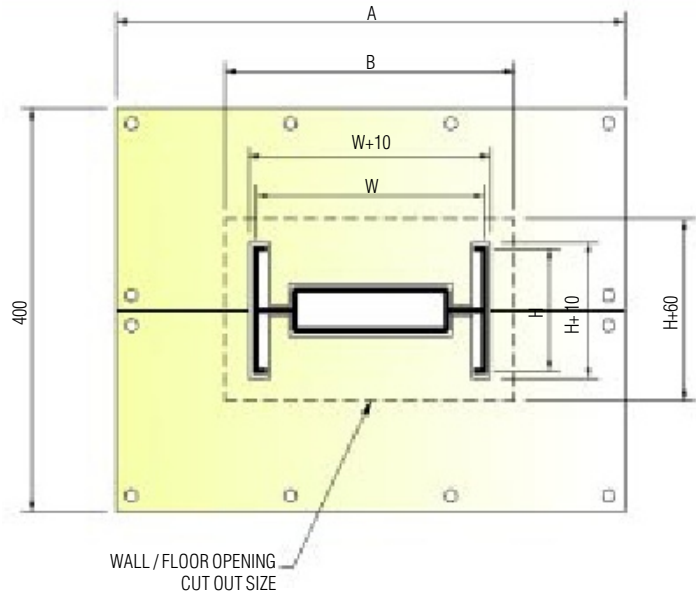
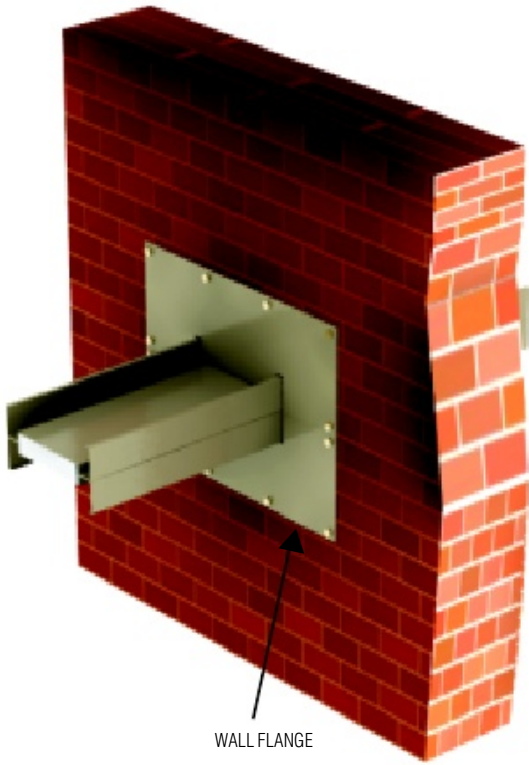

Figure 5

Ampere (A)		Fig.	A (mm)	B (mm)	Thickness (mm)	Length (mm)
Copper	Aluminum					
400	-	1	40-1	-	8	360
630	400	1	55-1	-	8	360
800	630	1	55-1	-	8	360
1000	800	2	75-1	40	8	360
1250	1000	2	100-1	50	10	360
1500	1250	3	125-1	40	10	360
1600	-	3	150-1	50	10	360
-	1500	4	175-1	40	10	360
2000	1600	4	185-1	45	10	360

Ampere (A)		Fig.	A (mm)	B (mm)	Thickness (mm)	Length (mm)
Copper	Aluminum					
2500	2000	5	240-1	45	10	360
3200	2500	3	150-2	50	10	360
3500	-	4	175-2	40	10	360
4000	3200	4	185-2	45	10	360
4500	3500	5	220-2	45	10	360
5000	4000	5	240-2	45	10	360
6300	4500	4	185-3	45	10	360
-	5000	5	240-3	45	10	360

### WALL FLANGE / FLOOR FLANGE



2

Ampere (A)		Stacks	Dimension (mm)		
Copper	Aluminum		W	A	B
400	-	1	115	380	175
630	400	1	125	390	185
800	630	1	130	400	190
1000	800	1	150	420	210
1250	1000	1	175	450	240
1500	1250	1	200	470	260
1600	-	1	225	500	285
-	1500	1	250	520	310
2000	1600	1	260	530	420
2500	2000	1	315	590	375
3200	2500	2	450	720	510
3500	-	2	500	770	560
4000	3200	2	520	790	580
4500	3500	2	590	860	650
5000	4000	2	630	900	690
6300	4500	3	780	1050	840
-	5000	3	945	1230	1005

### PLUG-IN / TAP-OFF BOX

#### A high degree of safety design

Henikwon SCM Busduct System's plug-in box is designed for a high degree of safety and is available in internal and external operation.

The plug-in / tap-off box comes with the following features:

- A built-in interlock system that prevents opening of the cover when the device inside is in "ON" position.
- A safety provision that will prevent the installation or removal of a plug-in box when turned to "ON" position.
- Plug-in hole is equipped with Class H insulation block which is fixed to the busbar to prevent any vibration which may cause any humming sound.
- Around the handle, there will be indication of colour codes and international "ON" and "OFF" switches.

#### Type of plug-in / tap-off box in a neutral position

The neutral terminal alignment is provided on the right side of the standard plug-in box.

#### Grounding

Before the jaws make contact with the busbar, the plug-in box enclosure shall make positive ground connection to the busduct housing.

#### Plug-in Box

##### External Operation

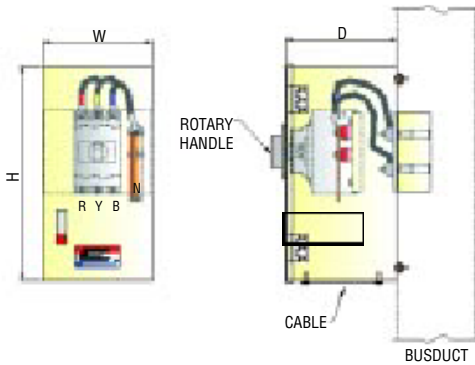

##### Internal Operation

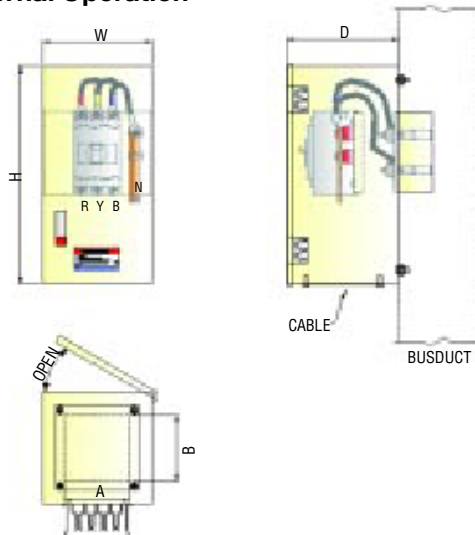

#### Tap-off Box

##### External Operation

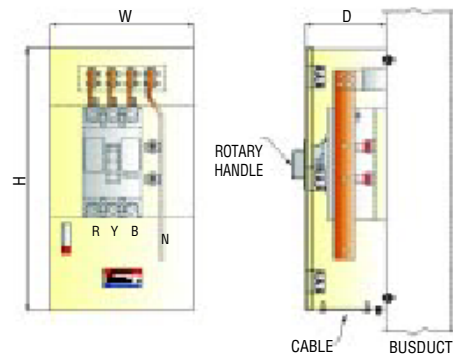

##### Internal Operation

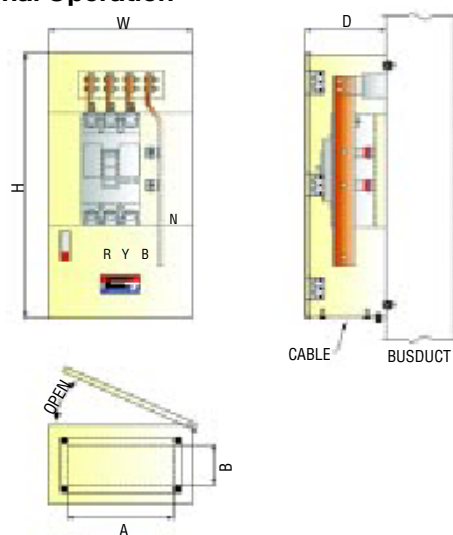

2

Frame	Dimension (mm)		
	W	H	D
30A ~ 100A	230	340	190
125A ~ 225A	230	370	200
250A ~ 400A	250	540	250
500A ~ 800A	360	840	250
1000A ~ 1200A	400	1000	300

Frame	Cable Hole (mm)	
	A	B
30A ~ 100A	120	60
125A ~ 225A	160	80
250A ~ 400A	180	120
500A ~ 800A	270	120
1000A ~ 1200A	300	150

Note: All dimensions are subject to change without prior notice.

Plug-in / Tap-off Box can be equipped with any brand of fused switches, MCCBs and etc, as per customer's requirement.

### DESIGN FACTORS FOR BUSDUCT LAYOUT

#### 1. MINIMUM DISTANCE BETWEEN PARALLEL-INSTALLED BUSDUCT

##### 1) In-Door Type (Edgewise Installation)

Busduct joints side by side

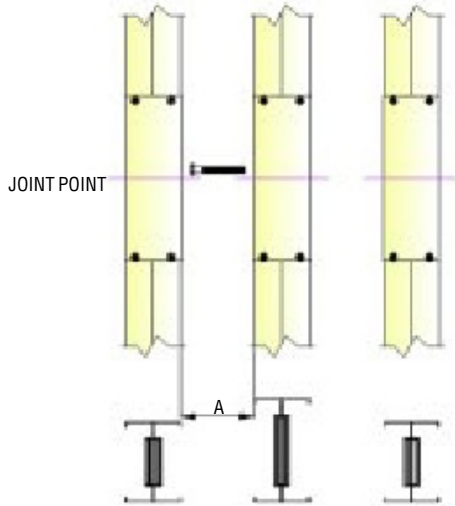

Busduct joints deviate from each other  
(Note: 'C' is above 190mm)

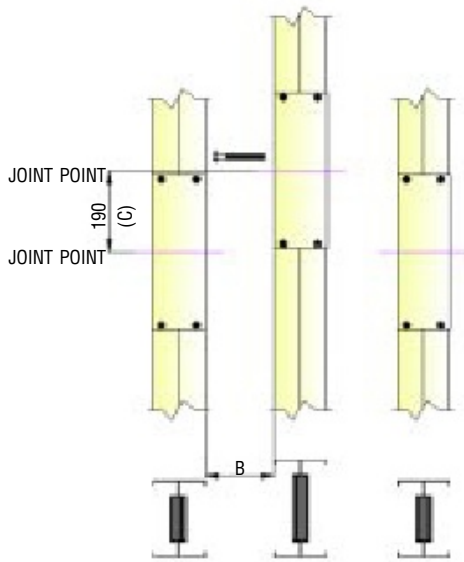

##### 2) Out-Door Type (Edgewise Installation)

Busduct joints side by side

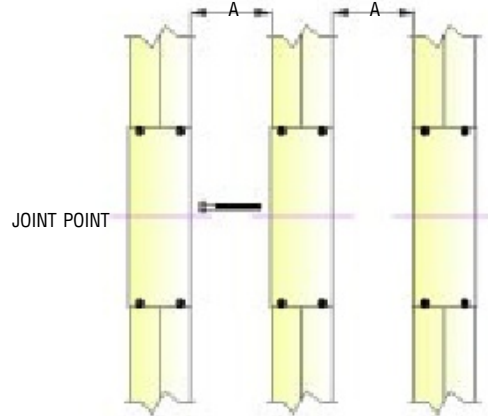

Busduct joints deviate from each other  
(Note: 'C' is above 395mm)

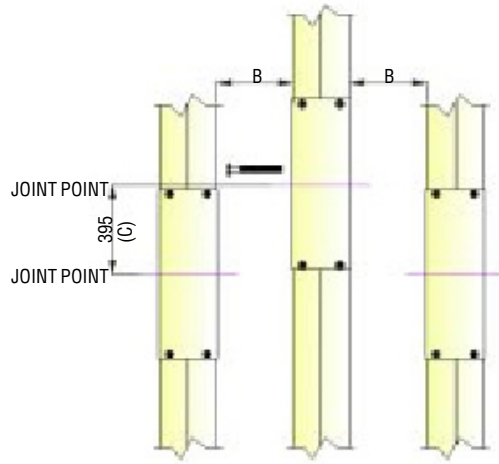

Ampere (A)	Dimension (mm): A		Dimension (mm): B	
	3W	4W-5W	3W	4W-5W
400 - 6300	150	160	85	95

Ampere (A)	Dimension (mm): A		Dimension (mm): B	
	3W	4W-5W	3W	4W-5W
400 - 6300	200	250	150	180

##### 3) In/Out-Door Type (Flatwise Installation)

Minimum clearance of busducts installed flat in parallel position

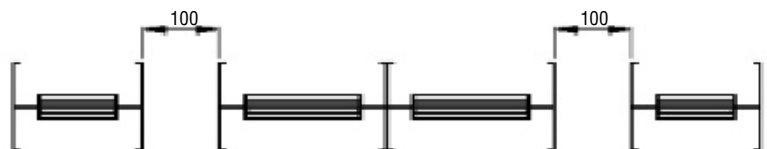

**4) Plug-In Type**

Minimum clearance of busducts installed flat in parallel position

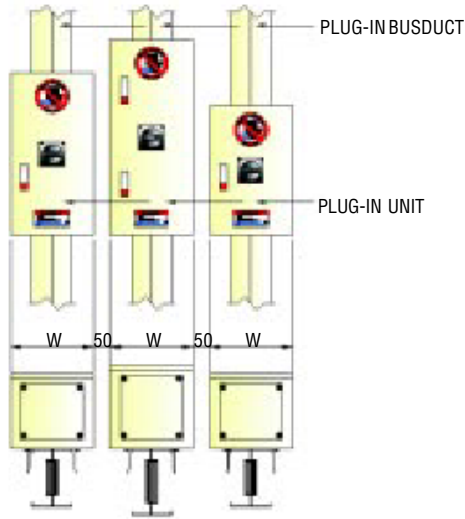

**2. MINIMUM CLEARANCE BETWEEN BUSDUCT, WALL, FLOOR AND OTHERS**

**1) Ceiling and Wall**

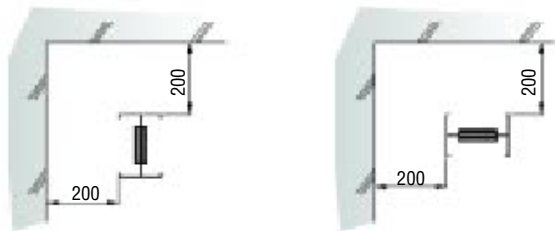

**2) Beam**

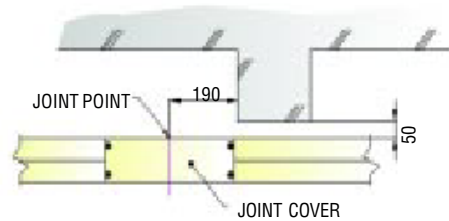

2

**3) Busduct jointing point through wall installation**

Indoor installation

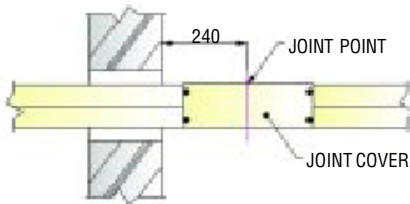

Outdoor/Indoor installation

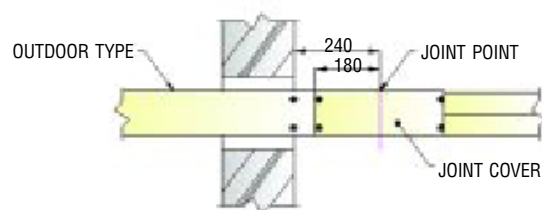

**4) Busduct jointing point and the floor/ceiling surface through floor installation as per Figure 1 and ceiling surface as per Figure 2.**

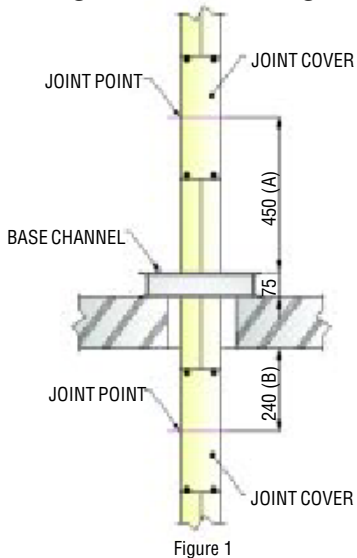

Figure 1

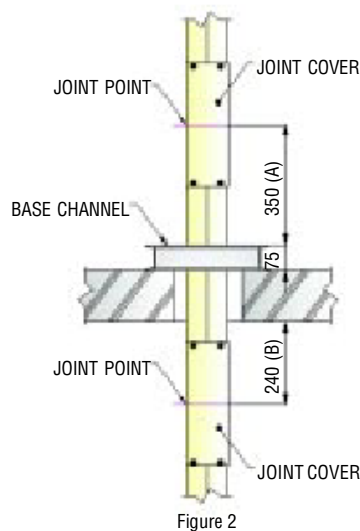

Figure 2

Joint should not be installed in between walls or floors.

Jointing point must be more than 240mm (B) from the surface of a ceiling.

If a vertical spring hanger is to be used on the floor, the distance must be more than 450mm (A). Otherwise, the distance must be more than 350mm, if vertical fix hanger is used.

*Note: Base channel is not include in our scope of supply.*

### 3. EXPANSION JOINT INSTALLATION

To determine the requirement of the expansion joint vertical busduct run, it will be according to how the busduct is supported at the two ends of the installation route; whether the busduct line is branched and what is the length of the busduct installation.

Supporting condition	Branching	Fig.	Length (L) which needs no expansion unit
Both ends free	Branched at each storey	1	120 (m)
One end free One end fixed	Branched at each storey	2	90 (m)
	Not branched	3	60 (m)
Both ends fixed	Branched at each storey	4	60 (m)

See the figures below for the use of the vertical hanger and vertical spring hanger.

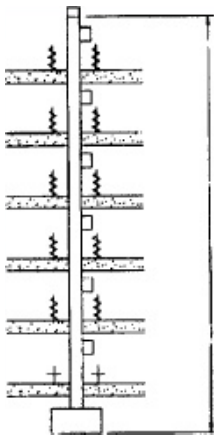

Fig. 1. L ≤ 120m

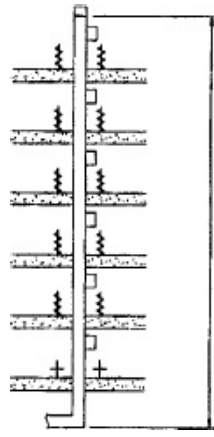

Fig. 2. L ≤ 90m

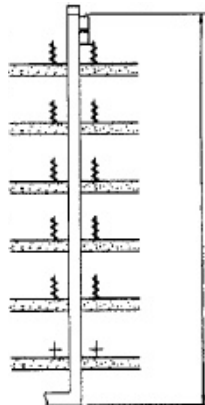

Fig. 3. L ≤ 60m

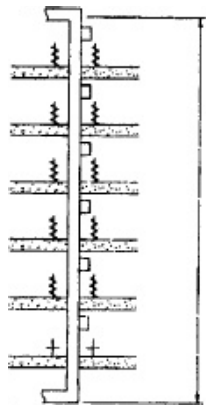

Fig. 4. L ≤ 60m

Note:

- Expansion joint is used in the case of installation deviating from the above condition.
- Expansion joint is designed and come in between the vertical hangers.

### 4. HANGER SUPPORT FOR HORIZONTAL RUN

Standard interval length between hangers = 1500mm

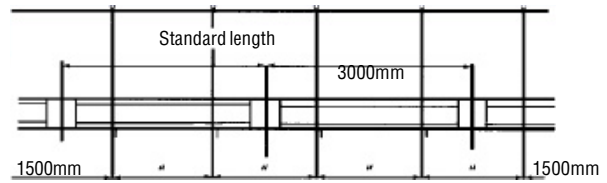

(Refer Page 19)

#### Size of hanger support

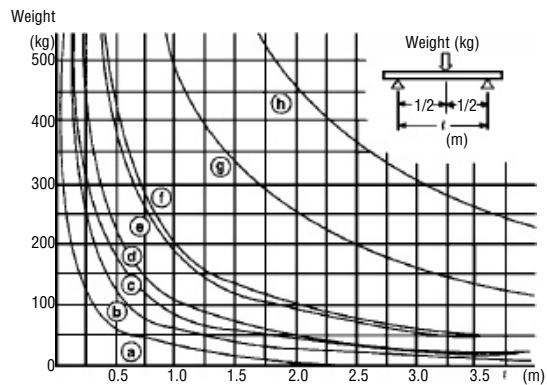

- Safety factor = 5
- Material of angle and channel is steel
- Bending stress =  $\frac{M}{Z}$

Z: Section Module      M: Bending Moment

#### Maximum bending moment & deflection (M)

$$M = \frac{W I}{4}$$

$$\delta = \frac{W I^3}{48EI}$$

Where: E = Young's Modulus  
I = Second moment of area  
 $\delta$  = Deflection

Specifications of various shape (steel)

Steel material size	Z (cm <sup>3</sup> )	I (cm <sup>4</sup> )	Weight (kg/m)
a Angle 40 x 40 x 3	1.21	3.53	1.83
b Angle 50 x 50 x 4	2.49	9.06	3.06
c Angle 50 x 50 x 6	3.55	12.60	4.43
d Angle 75 x 75 x 6	8.47	46.10	6.85
e Channel 75 x 40 x 5	5.54	12.40	6.92
f Channel 100 x 50 x 5	7.82	26.90	9.36
g Channel 75 x 40 x 5	20.20	75.90	6.92
h Channel 100 x 50 x 5	37.80	189.00	9.36

Z : Section modulus  
I : Second moment of area

Note:

- Lifting Bolt size is 12mm.
- Do not overlap lifting bolt and joint part.
- Hanger interval standard length is 1.5m.
- In case of the plural busduct installation, one hanger system can be selected.

## INSTALLATION MANUAL

The following procedures are precautions that must be adhered in handling SCM Busduct System.

Installation according to the below instructions shall achieve a total performance of SCM Busduct System.

### 1. GENERAL PRECAUTIONS

#### 1.1. Storage

- i) All unit numbers shall be checked against the packing list upon arrival of the goods/consignment.
- ii) Also to check for any damages on busduct units that may occur during transportation.
- iii) Store the busduct in a dry place to protect it from being soiled or damaged. If necessary, cover the busduct with water proof sheets.
- iv) Do not lay the busduct directly on the ground. Always place pieces of wood under the busduct and stack up firmly as shown below. Never put it upright during storage or installation.

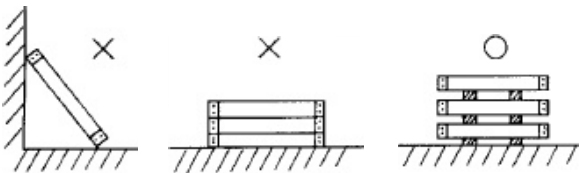

- v) Cover the ends of the busduct unit with a vinyl sheet till immediate installation to prevent it from being soiled.

#### 1.2 Preparation

- i) Check the busduct laying route thoroughly to see if there are any obstacles, i.e. heat source, water leakage, etc.
- ii) To standardized the installation of the busduct, the hanger pitch should be set to support two sections to one unit.
- iii) Site conditions are to be investigated before hand to determine the most appropriate laying order. The installation starts from connecting of busduct to transformer or switchboard. If the position of elbows T-branch cannot be determined precisely, then the selection on another position/point would have to be determined for.

#### 1.3 Laying

- i) Fork lift or similar is used for transportation and lifting. The weight per one meter of SCM Busduct System is given in the table on page 11. However, special busduct sometimes may weigh more than those shown in the table.

- ii) To prevent the busduct from being damaged when hanging it with a rope, insert thick pieces of rag or corrugated cardboard between them. For copper busduct rated 2500A and above, a piece of strong wood is recommended to be used to withstand the weight.
- iii) Ensure that there are no damages to the conductor contact surface and insulating materials before jointing of the busduct. Also to ensure they are not soiled with debris and other foreign matter, if there is any, clean them thoroughly with dry cloth.
- iv) Make loose joint of busducts over the whole run. After measuring the dimensions, proceed with the normal jointing. SCM Busduct System allows dimensional adjustment of approximately  $\pm 3\text{mm}$ , at each joint.
- v) If a megger value is found to be abnormal after jointing the whole route, it means that much time is needed to detect faulty parts. It is therefore recommended that the megger checking to be partially conducted even during the joint work.
- vi) If the work is temporary halt during construction, then the ends of the connecting section should be protected against water and dust.
- vii) Do not use the installed busduct as a scaffold or material yard.

2

### 2. JOINTING PROCEDURE

#### General

The following procedures are for the assembly of SCM Busduct System jointing section. Check the directions of the load and supply side of the busduct jointing part as shown in the diagram below.

HENIKWON SCM Busduct System is delivered to the site with the joint parts completely sealed with plastic to avoid any moisture ingress during transportation and storage. The joint part is tin-electroplated to prevent any corrosion and moisture from forming.

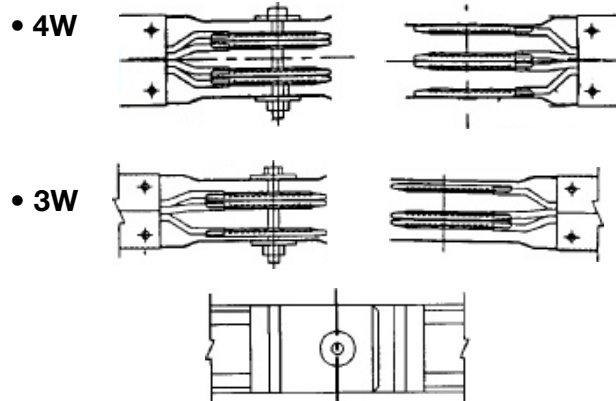

Able to insert from either direction.

### 3. JOINTING METHOD

The most important section of the busduct system is the jointing part in order to avoid heating, voltage drop and etc. The following procedures are to ensure a continuous satisfactory operation and integrity of the busduct system.

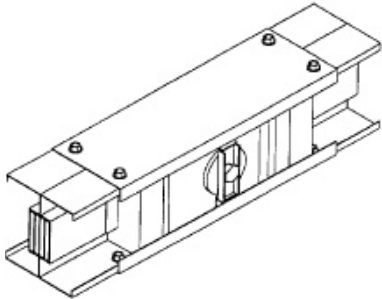

ASSEMBLY COMPLETED

- 3.1 Ensure the jointing direction of load and supply sides are confronting each other before jointing. Place the inserting tool in order to make sure that both holes of the busbar conductor are aligned with each other.
- 3.2 Make sure the contact surfaces of the busbar conductor are smooth and clean to ensure a good electrical contact.
- 3.3 Insert the joint bolt completely with the joint support and Belleville washer. Once through the busduct jointing, the hole will be closed with Belleville washer and maintenance free nut.
- 3.4 Make sure that the bolts have a complete and proper fastening in order to get enough tightening. Revolve the outer nut clockwise until the neck part of the bolt breaks.
- 3.5 Fix the joint covers at the front and the back of the jointing part with bolt and nut. The joint covers have four housing mounting holes that contain twist-outs that would permit the expansion or contraction of the joint.

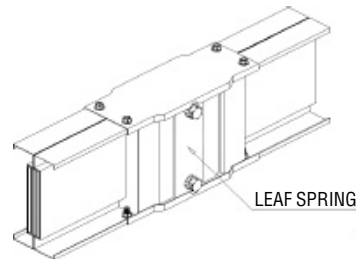
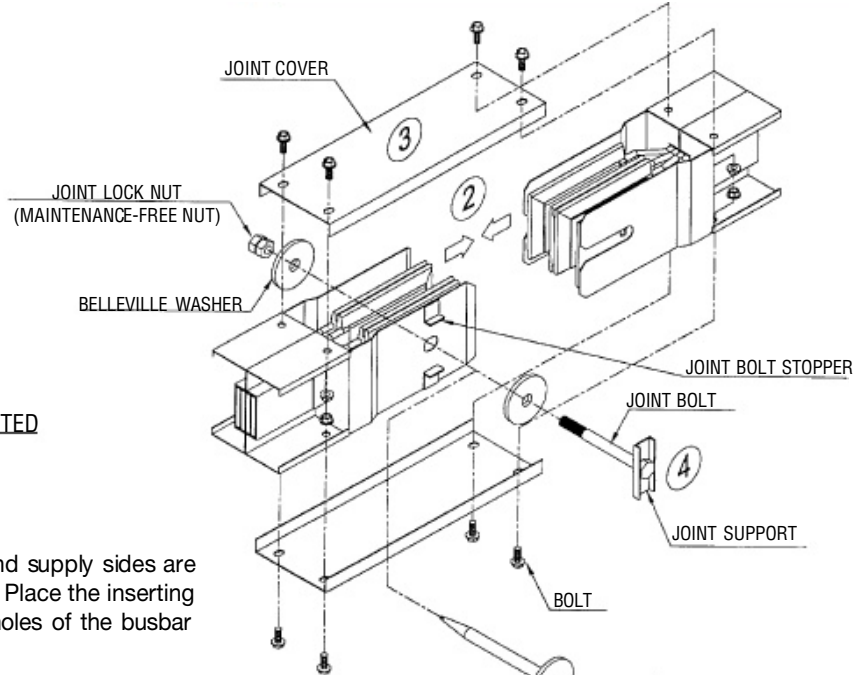

For 1600A, 2000A, 3200A, 3500A, 4000A, 4500A, 5000A aluminum busduct system, joint system with leaf spring is used.

### MAINTENANCE FREE NUTS

HENIKWON SCM Busduct System provides a reliable and complete fastening of joint bolts, with a maintenance-free nut system. The maintenance-free nut system, as shown in the below diagram, consists of an inner Thread and Torque Limited Neck.

When a MF NUT is fastened by the torque wrench with the requirement torque of 1500kg•cm and simultaneously. Later, the outer NUT head, which can be tightened with any long-handle wrench until the neck is twisted off and reaches the locked nut prerequisite.

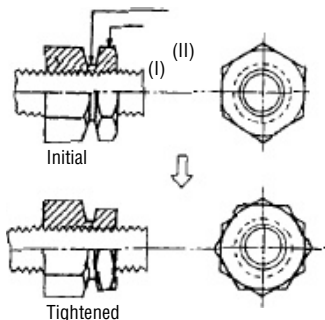

### SAFETY POINT

1. Upon fastening and locking of joint bolts, Nut (I) will either be taken off or dropped. This indicates a proper safety of a fastened locked Nut.
2. Lock with twisted force will remain even though Neck (II) is broken in the process.

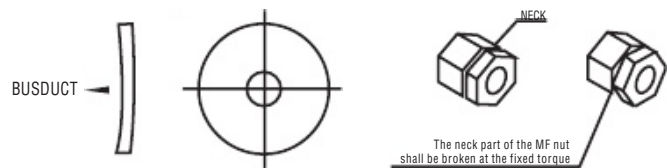

BELLEVILLE WASHER

MAINTENANCE-FREE NUT

### 4. ACTUAL MEASUREMENT

If there is any remaining portion from the actual measurement, then the measurement shall be taken from point A to point B as shown in the diagram below.

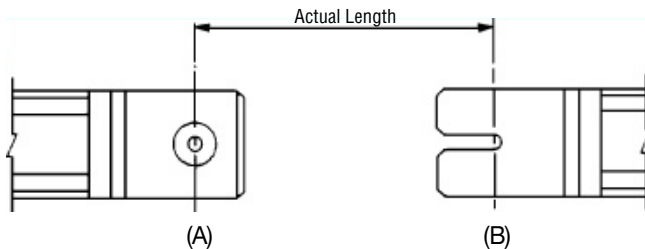

### 5. CONNECTION WITH EQUIPMENT

Note followings when jointing the busduct with the transformer and switchboard.

Apply the under mentioned values as a yardstick for the clamping torque of the conductor clamping bolt.

Bolt Size	Clamping Torque (kg•cm)
M8	90 - 110
M10	180 - 230

### 6. HORIZONTAL HANGER INSTALLATION

- 6.1 Fix horizontal hanger to the hanger rod and adjust it for correct elevation of the busduct as per site condition.
- 6.2 Lay the busduct on the horizontal hanger.
- 6.3 Install the hanger clamp on both side of the busduct for fixture.
- 6.4 Ensure the busduct is aligned in straight line.
- 6.5 Additional horizontal hangers shall be placed on elbows, such as vertical / horizontal elbow, offset elbow, combination elbow and etc.
- 6.6 Supporting interval of horizontal hanger shall not exceed 1.5 metres.

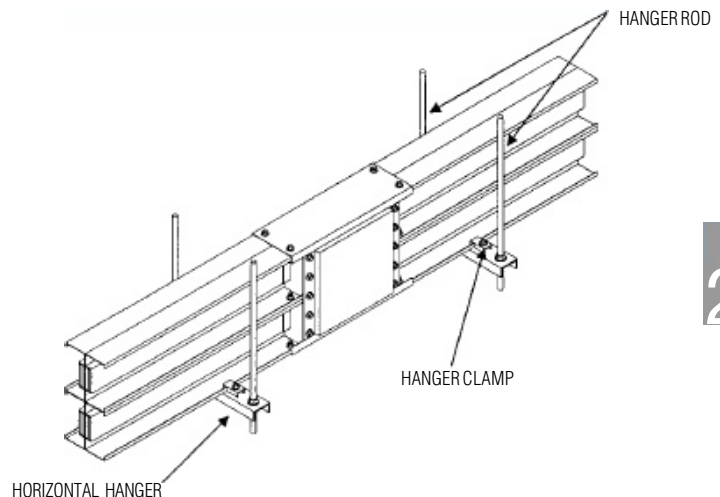

2

### 7. VERTICAL SPRING HANGER INSTALLATION

For Vertical Spring Hanger, they are used on subsequent floors to absorb any expansion occurrence from busduct. Moreover, immediate support shall be provided if the floor-to-floor distance exceeds 5 meters.

The following instructions are for fitting of Vertical Spring Hanger for Henikwon Busduct System.

- 7.1 Temporarily support the busduct section in place. Fit the C-Channel (customer supply) onto the Floor Flange. Fix on the bolts (customer supply) onto the Slab in order to hold the C-Channel firmly to the Slab.
- 7.2 Drill the C-Channel with opening hole of  $\phi 14\text{mm}$  to accommodate the fixed support rod. Locate the hole in line with the centerline of the side of the busduct housing. The distance in between these two holes from center to center is 65mm [E]. (Figure 1)  
  
Then, drill the busduct housing with opening hole of  $\phi 12\text{mm}$  with the height around 190mm [F] from the top of the C-Channel for installing the L-Channel Bracket by using M10 bolts supplied. The distance in between these two holes from center to center is 60mm [G]. (Figure 1)
- 7.3 Fix the rod to the top of the C-Channel together with the nuts as shown in [1].

Try to adjust the Top Nut on both sides until the height from the bottom of the L-Channel to the top of the C-Channel is around 155mm as shown in [H], while the height from the bottom of L-Channel to the bracket of the Vertical Spring Hanger is 100mm as shown in [J].

Then, fix the L-Channel together with the nuts as shown in [2]. (Figure 2)

- 7.4 Unscrew the top nut, 15mm [K] above the top of the L-Channel. The process of installing Vertical Spring Hanger is completed.

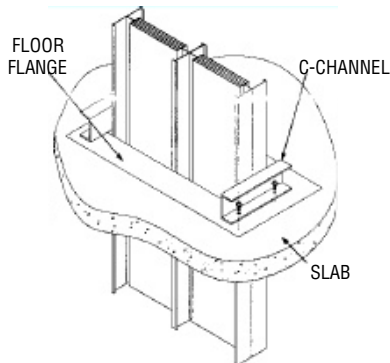

Figure 1

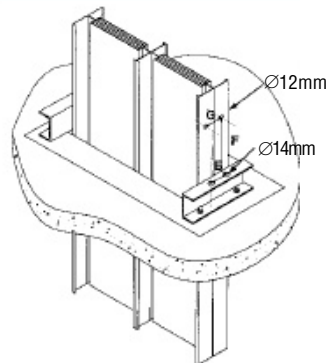

Figure 2

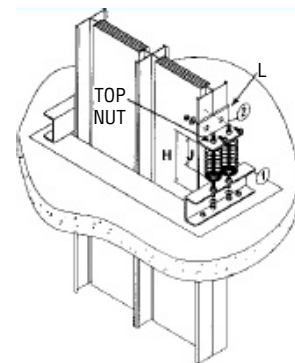

Figure 3

## 8. TEST AND CHECKING AFTER INSTALLATION

Check the whole route, mainly the points below at the same time with the measurement of insulation resistance of the whole structure being carried out once the laying of the busduct is completed.

When carrying out the measurement of the insulation resistance, disconnect the equipment after the plug-in box is installed. Once breaker has set to 'OFF' position (conduct the measurement).

The insulation resistance value cannot be specified due to the differences of the length of the route and the environmental factors. In a dried atmosphere, it would give a value of approximately 100MW (500V Megger). If it is below 10MW, it has to be checked due to some factors that can reduce the insulation and the other factors can be as follow;

- 1) Whether the busduct is damaged,
- 2) Whether the connecting parts are fixed precisely,
- 3) Whether the bolts for connecting the equipment are securely fastened,
- 4) Whether the hangers are supporting the busduct securely,
- 5) Whether the vertical spring hanger is fixed properly.

## 9. MAINTENANCE AND CHECKING

The following check points are recommended to ensure a long period of safe usage and maintenance of the busduct system:

### 9.1 Check the external appearance

Check whether there are any deformation, damage, dirt and etc., throughout the whole run of the busduct and whether there is dislocation, bending and other abnormality of connecting cover, hanger and plug-in appliances.

### 9.2 Environmental check

The environment, where the busduct is used, may change after the installation. Check whether the environment has become hazardous even partially due to water, moisture, high temperature, corrosive gas, immoderate vibration, dust and etc.

### 9.3 Check the joint connection section

There will be no problem of loosening at the joint connection of SCM Busduct by 'concordance' as maintenance free nut system. Therefore, a periodical increased clamping is unnecessary. However, when the contact surface is soiled or deteriorated during the construction or during storage, a simple check by touching the external portion during the current sending is recommended as the above effects would gradually arise. If the temperature of the connecting section and the main body is about the same, then there will be no problem.

### 9.4 Check the load condition

Increase of load is expected at the early stage after the installation of the busduct. Check the total load is not exceeding the capacity of the busduct at the time of the increased in load. Closely monitor especially when the mainline is branched by T-branch or cross.

### Merits

1. **Safe Operation**  
There is absolutely no shock at the time of cutting such as torque bolts and operation at elevated spot is also safe.
2. **Great Reliability**  
As regards to the conventional torque management, it is difficult to obtain constant clamping force due to dispersion of the coefficient of friction.

HIGHBAR is a non-segregated phase bus ducts designed for inter-connecting groups of metal-enclosed or metal-clad switchgear, power transformers or other related equipment providing a wide range of ratings to allow proper application for a variety of installation conditions. Available in copper or aluminum conductors and all conductors are individually supported on epoxy insulators. The bus duct is designed, manufactured and tested in accordance with IEC62271-200:2003.

## GENERAL SPECIFICATION

### Features

- **Custom Engineered** – The entire busduct system is specifically designed to suit the requirements of each installation.
- **Simple jointing system** – It enables a quick installation.
- **Low Installation Cost** – Field installation requires only placing the busduct sections on the supports, bolting splices, and connecting the ends to the apparatus terminals.
- **High Basic Impulse Insulation Levels** – The basic impulse level of the busduct is equal to that of the associated switchgear or other equipment.

### Sturdy Constructed Housing

The indoor busduct is a total enclosed and gasketed non-ventilated housing. Outdoor busduct is totally enclosed and gasketed. Epoxy powder painted aluminum, electro-galvanized steel or stainless steel housings are available to meet the variety of environment concerns. Ventilated indoor busduct with louvers are available.

### Busbar

The busduct conductor is available in either tin-plated or silver plated at contact surface of a copper bus bar with conductivity at 99.9% or aluminum busbar, per customer's specifications. Busbar is supported with flame retardant epoxy insulator to have a firm hold against the movement during short-time current. Internal or external ground bars or neutral bars are available as required.

### Joints

Where splice plates are required, they are equal in cross section to the main busduct.

### Space Heaters / Thermostat

As per customer's requirement, space heaters or thermostats are mounted inside the outdoor housings to prevent condensation, and detect the temperature changes, spaced approximately 2 meters along the length of outdoor busduct run.

### Busduct Supports

Custom designed busduct support structures are available to meet the site condition, for both in indoor and outdoor installations to support the busduct runs.

### Earth System

Internal earth system is fixed in the busduct.

### Accessories

A complete line of elbows, tees, terminations for transformers and switchgear phase transpositions, expansion joints, wall flanges, flexible conductors, bushing boxes, bushing stud connectors and terminal enclosures are available.

### Short-time Current Capacity

Conductors are firmly secured against movement during short time current to high rated levels.

### Application Data

- 1) Operating voltage: 3.6kV – 36kV
- 2) Withstand voltage: 10 – 195 kV
- 3) Rated current: 400 – 5000A
- 4) Conductors: Copper or aluminum
- 5) Degree of Protection:  
Indoor / weather-proof – IP54, Outdoor – IP55 & IP67
- 6) Standard: IEC62271-200: 2003



### PRODUCT SELECTION

#### FEEDER



#### VERTICAL ELBOW



### DIMENSIONS

#### 1. 3.6KV CLASS 3 WAY

Ampere (A)	Conductor (mm)	Dimension (mm)						Weight (kg/m)	
		Indoor			Outdoor			Indoor	Outdoor
		S	W	H	S	W	H		
400	5x55-1	150	600	400	150	600	400	59	62
630	6x55-1	150	600	400	150	600	400	61	64
800	5x75-1	150	600	400	150	600	400	62	65
1000	6x80-1	165	650	400	165	650	400	68	71
1250	6x100-1	180	700	400	180	700	400	74	77
1500	10x100-1	180	700	400	180	700	400	85	89
1600	12x100-1	180	700	400	180	700	400	91	95
2000	12x80-2	165	650	425	165	650	425	110	115
2500	10x100-2	180	700	425	180	700	425	115	120
3200	12x125-2	200	750	425	200	750	425	145	152
3500	12x150-2	230	850	425	230	850	425	168	176
4000	12x125-3	200	750	450	200	750	450	189	198
4500	12x150-3	230	850	450	230	850	450	220	230
5000	12x170-3	250	900	450	250	900	450	243	254

#### 2. 7.2KV CLASS 3 WAY

Ampere (A)	Conductor (mm)	Dimension (mm)						Weight (kg/m)	
		Indoor			Outdoor			Indoor	Outdoor
		S	W	H	S	W	H		
400	5x55-1	160	650	400	160	650	400	62	65
630	6x55-1	160	650	400	160	650	400	64	67
800	5x75-1	175	700	400	175	700	400	68	71
1000	6x80-1	175	700	400	175	700	400	70	74
1250	6x100-1	190	750	400	190	750	400	77	80
1500	10x100-1	190	750	400	190	750	400	88	92
1600	12x100-1	190	750	400	190	750	400	93	98
2000	12x80-2	175	700	425	175	700	425	112	118
2500	10x100-2	190	750	450	190	750	450	118	124
3200	12x125-2	225	850	425	225	850	425	151	158
3500	12x150-2	240	900	425	240	900	425	170	178
4000	12x125-3	225	850	450	225	850	450	194	203
4500	12x150-3	240	900	450	240	900	450	222	233
5000	12x170-3	275	1000	450	275	1000	450	248	260

### HORIZONTAL ELBOW



### PHASE TRANSPOSITION UNIT



### 3. 12KV CLASS 3 WAY

Ampere (A)	Conductor (mm)	Dimension (mm)						Weight (kg/m)	
		Indoor			Outdoor			Indoor	Outdoor
		S	W	H	S	W	H		
400	5x55-1	200	800	500	200	800	500	75	78
630	6x55-1	200	800	500	200	800	500	76	80
800	5x75-1	225	900	500	225	900	500	83	87
1000	6x80-1	230	900	500	230	900	500	86	90
1250	6x100-1	250	950	500	250	950	500	92	96
1500	10x100-1	250	950	500	250	950	500	103	108
1600	12x100-1	250	950	500	250	950	500	109	114
2000	12x80-2	230	900	550	230	900	550	129	135
2500	10x100-2	250	950	550	250	950	550	134	140
3200	12x125-2	275	1050	550	275	1050	550	167	175
3500	12x150-2	300	1100	550	300	1100	550	187	196
4000	12x125-3	275	1050	550	275	1050	550	209	219
4500	12x150-3	300	1100	550	300	1100	550	237	249
5000	12x170-3	315	1150	550	315	1150	550	260	273

3

### 4. 24KV CLASS 3 WAY

Ampere (A)	Conductor (mm)	Dimension (mm)						Weight (kg/m)	
		Indoor			Outdoor			Indoor	Outdoor
		S	W	H	S	W	H		
400	5x55-1	275	1150	650	275	1150	650	100	105
630	6x55-1	275	1150	650	275	1150	650	102	106
800	5x75-1	300	1200	650	300	1200	650	106	111
1000	6x80-1	300	1200	650	300	1200	650	108	114
1250	6x100-1	315	1250	650	315	1250	650	115	120
1500	10x100-1	325	1300	650	325	1300	650	128	135
1600	12x100-1	325	1300	650	325	1300	650	134	141
2000	12x80-2	300	1250	700	300	1250	700	154	161
2500	10x100-2	325	1300	650	325	1300	650	157	164
3200	12x125-2	350	1350	700	350	1350	700	190	199
3500	12x150-2	375	1450	700	375	1450	700	212	222
4000	12x125-3	350	1350	700	350	1350	700	232	243
4500	12x150-3	375	1450	700	375	1450	700	263	275
5000	12x170-3	390	1500	700	390	1500	700	286	300

Henikwon AIRDUCT system is totally metal enclosed air-insulated busduct system which complies to the characteristics and structure specified in BS5486/2, IEC60439-2, JIS C8364, NEMA, ANSI and CSA.

Small capacity of power supply systems are being used widely for various factories, machine shops, school laboratories and commercial buildings, where modern and simple wiring system is required for more economical power supply connecting to the equipments, machines, lighting facilities and many others.

Most of indoor location where there is a need for small blocks of conveniently available power, HENIKWON AIRDUCT System serves as a highly rationalized power supply system with various features.

With total ten plug-in holes per 3000mm unit are available for various capacity ranges of the AIRDUCT System, which really demonstrates its superb functions.

## GENERAL SPECIFICATION

### Features

- High Safety
- Custom Engineered
- Compact & Light-weighted
- Easy Installation
- Low Installation Cost
- Economical
- Quick Delivery
- Easy Expansion & Relocation
- Can Be Branched out Anywhere

### Sturdy Constructed Housing

The indoor busduct is a total enclosed and gasketed non-ventilated housing structured in epoxy powder painted electro-galvanized steel.

### Busbar

The bus duct conductor is available in tin-plated 99.9% copper conductivity busbar. Busbar is supported with glass fiber reinforced SMC insulator which stands above 180°C, holding firm against the movement during short-time current. Internal or external ground bars or neutral bars are available as required.

### Joints

Direct joint system results a better connection.

### Earth System

Internal ground system is available.

### Short-Time Current Capacity

Conductors are firmly secured against movement during short time current.

### Accessories

A complete line of elbows, tees, terminations for transformers and switchgear, floor flanges, flexible conductors, enclosures are available.

### Application Data

- 1) Operating voltage: 415V
- 2) Withstand voltage: 10 kV
- 3) Rated current: 100 - 400A
- 4) Conductors: Copper
- 5) Degree of Protection:  
Indoor / weather-proof – IP54, Outdoor – IP67
- 6) Standard: IEC60439-2: 2005

### • Application for Factories

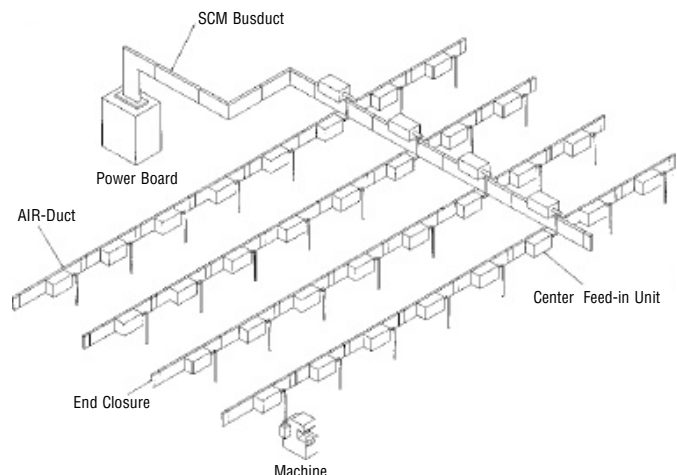
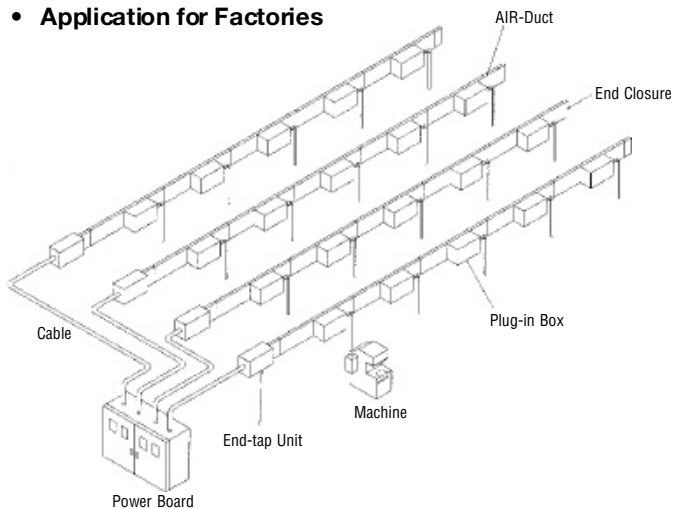

**PRODUCT SELECTION**

**FEEDER (PLUG-IN)**

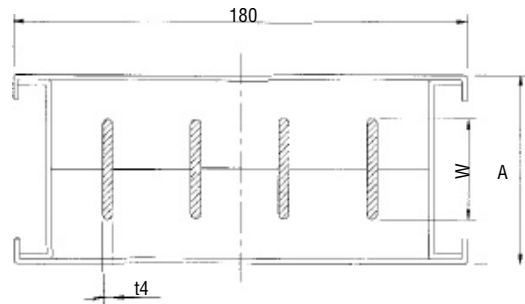
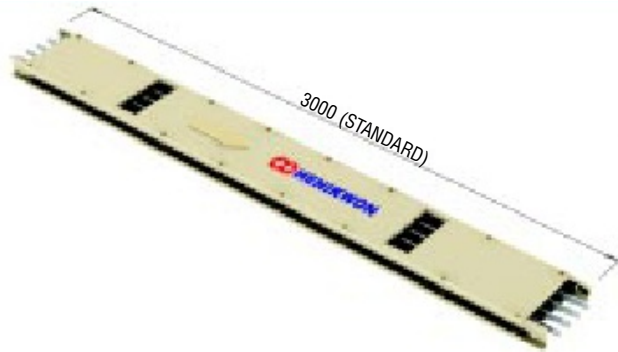

Ampere (A)	Conductor (mm)		Dim (mm) H	Impedance R: 50Hz	Volt. Drop X: 50Hz	Weight (kg/m)
	T	W				
100 ~ 200	4	20	55	$2.18 \times 10^{-4}$	$1.07 \times 10^{-4}$	7.5
225 ~ 400	4	40	75	$1.28 \times 10^{-4}$	$0.80 \times 10^{-4}$	10.8

**VERTICAL ELBOW**

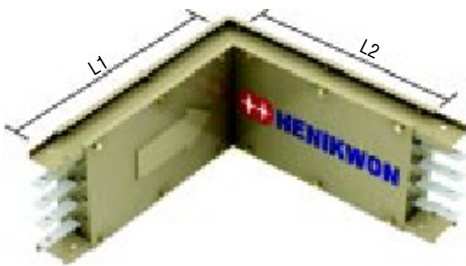

**HORIZONTAL ELBOW**



Standard(mm) L1 x L2	Min. (mm) L1 x L2
300 x 300	100 x 100

Standard(mm) L1 x L2	Min. (mm) L1 x L2
300 x 300	150 x 150

4

**POWER FEED-IN**

**Center Cable Feed Box**

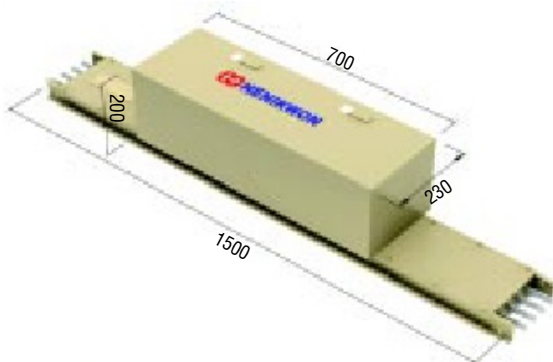

**Cable Feed Box**

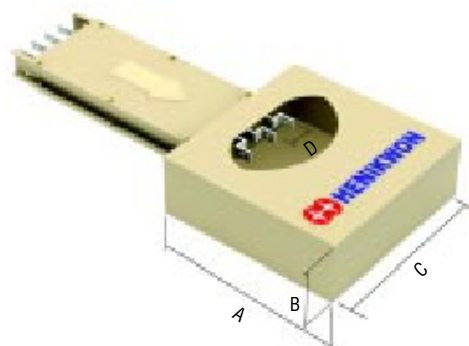

Ampere (A)	Dimension (mm)			
	A	B	C	D
100 ~ 200	350	120	350	80
225 ~ 400	350	140	350	80

### FLOOR FLANGE

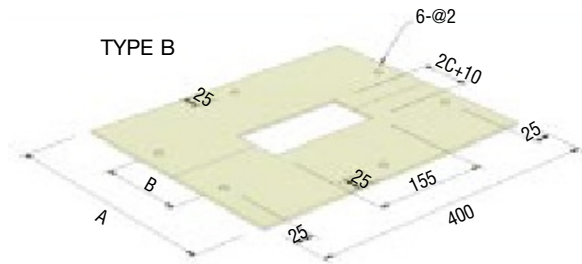
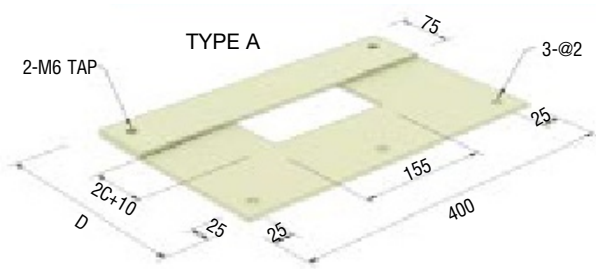

Ampere (A)	Dimension (mm)			
	A	B	C	D
100 ~ 200	320	120	30	250
225 ~ 400	350	150	40	280

### HANGERS

#### Hanger for Flatwise Installation

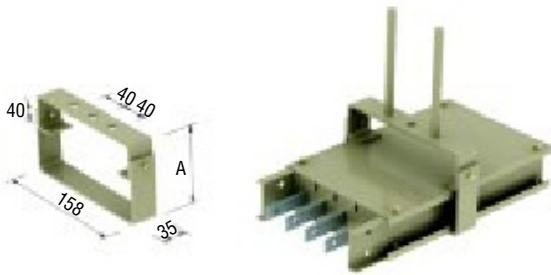

Ampere (A)	Dimension : A (mm)
100 ~ 200	110
225 ~ 400	130

#### Hanger for Edgewise Installation

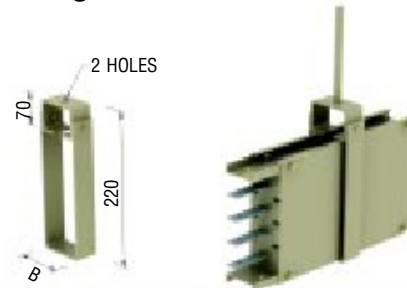

Ampere (A)	Dimension : B (mm)
100 ~ 200	60
225 ~ 400	80

#### Vertical Fix Hanger

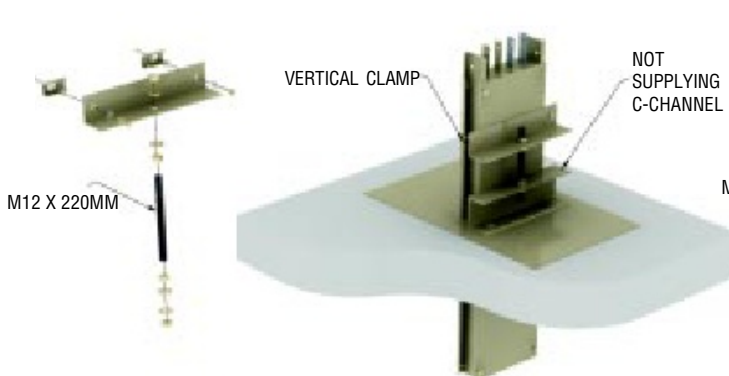

#### Vertical Spring Hanger

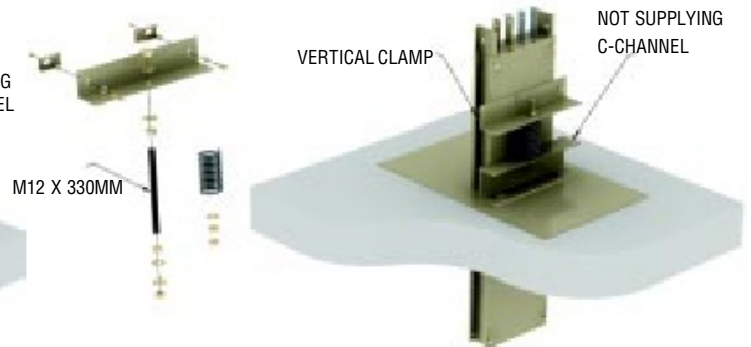

### Plug-In Box

#### • External Operation

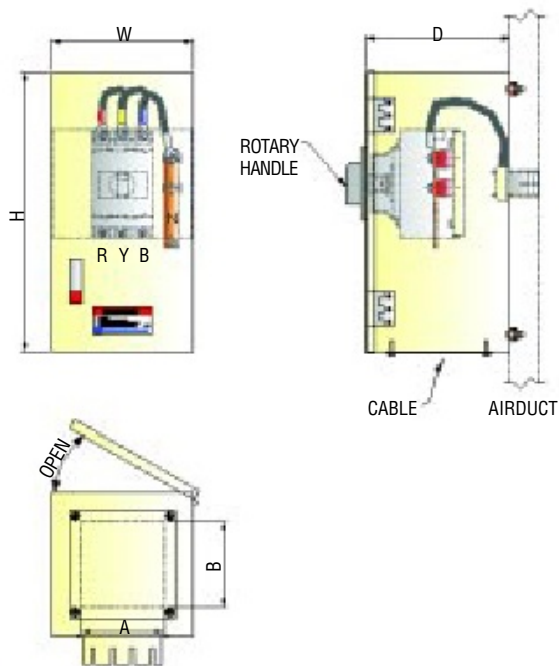

### Plug-In Box

#### • Internal Operation

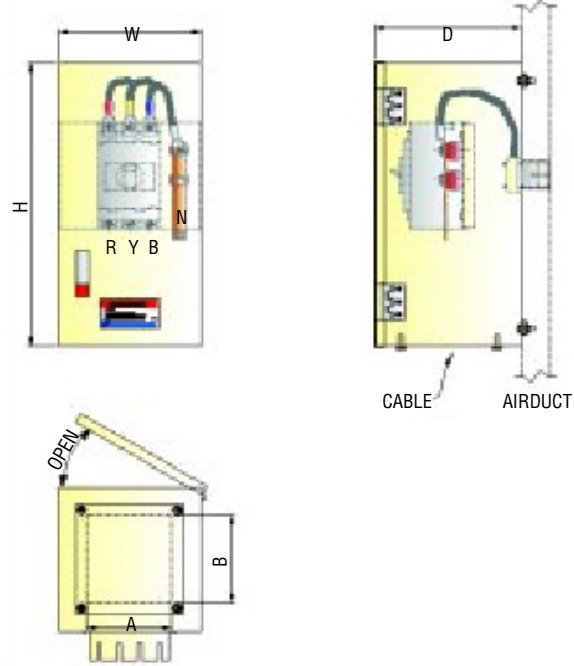

Frame	Dimension (mm)		
	W	H	D
30A ~ 100A	230	340	190
150A ~ 200A	230	370	200

Frame	Cable Hole (Ø)	
	A	B
30A ~ 100A	120	60
150A ~ 200A	160	80

**Note:** All dimensions are subject to change without prior notice.

Plug-in Box can be equipped with any brand of fused switches, MCCBs and etc, as per customer's requirement.

4

## SAFETY LOCK MECHANISM

### 1. Ground-Cases Safety

The Air Duct case is safely grounded with earth springs and they are the first to come in contact with the casing when the plug-in box is attached to the air duct.

### 2. Safe, "Neutral First" Plug Connecting

When a plug-in box is attached to the busduct, the neutral line is the first to connect forming a solid neutral circuit. Likewise, the neutral plug is the last to break circuit when disconnecting the plug-in box from the air duct to provide total neutral line priority over all of the energized lines.

### 3. Box Interlock

When the door is open, the plug-in box can be affixed firmly to the air duct. If it is closed, it will not be possible to remove the plug-in box from the air duct.

### 4. Door Interlock

When the plug-in box door is closed and the handle is in "ON" position, the door will automatically be locked and the MCCB will be activated. If the door interlock is released by turning the lock handle to "OFF" position, the MCCB will be energized and the door is ready to open.

### INSTALLATION MANUAL

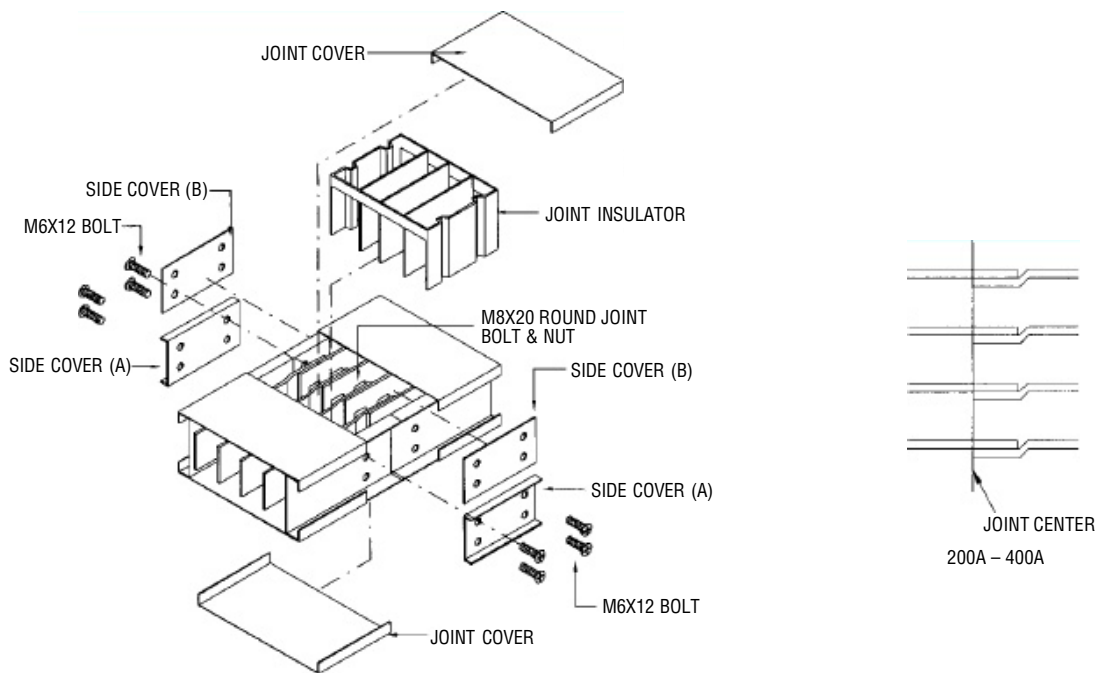

### JOINTING METHOD

- (1) Align two units of Air Duct to be jointed.
- (2) Overlap conductor edges exactly as shown above.
- (3) Fix casings with nut plates and side covers on both sides.
- (4) Connect conductors of each phase with bolts and nuts. Fit in blue coloured face of Belleville washers turned inside.
- (5) Insert an insulation barrier inside joint.
- (6) Fix the ground bar for jointing part to the ground bar attached with the side of Air Duct.

### HANDLING

Proper handling, installation, inspection and maintenance will preserve Air Duct excellent properties and ensure trouble-free operation for a long time.

#### 1. Transportation and Storage

- 1.1 Store Air Duct in cool and a dry place.
- 1.2 When transporting the Air Duct, do not drop or let it hit other objects.
- 1.3 When storing Air Duct, check the number of all units.
- 1.4 Keep Air Duct up off the floor using wooden spacers.
- 1.5 During storage, make sure that the Air Duct is protected from moisture and damage.

#### 2. Installation

- 2.1 Check the layout design of the Air Duct before setting to work.
- 2.2 Do not drop or let the Air Duct hit other objects when carrying it out from the storage.
- 2.3 Use hangers (horizontal run) to support each unit of Air Duct at the two points.

2.4 For vertical installation, Air Duct will be supported by the floor.









2.5 Make sure that Air Duct jointing is done correctly and firmly.

#### 3. Inspection and maintenance

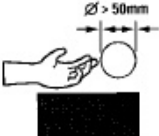
- 3.1 If it has been correctly and thoroughly inspected after installation, Air Duct will provide basic maintenance-free service.
- 3.2 It is best to inspect the Air Duct periodically and provide maintenance as and when required to ensure its original top-level performance for a longer period of time where it is being used as an important trunk line.
- 3.3 Check the Air Duct thoroughly whenever it has been subjected to unusual conditions such as having been jolted by earthquake, exposed to fire or contaminated by water or other foreign matter.

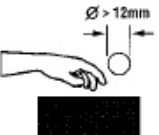
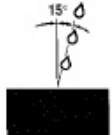
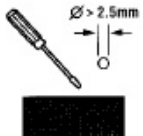
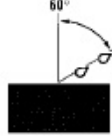
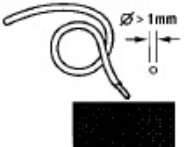
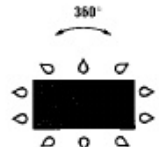
### IEC STANDARD INTERNATIONAL PROTECTION (IP)

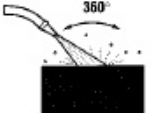
IEC Publication 60529 Classification of Degrees of Protection by Enclosures provides a system for specifying enclosures of an electrical equipment based on the degree of protection required.

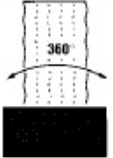
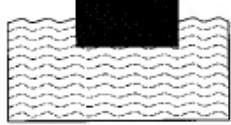
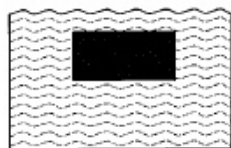
Protection against touch and foreign bodies		Protection		Protection against water		
Touch	Foreign body	first figure IP	second figure IP			
no protection 	no protection	<b>0</b>	<b>0</b>	no protection 	Technical Information	
accidental touch with large areas of the body (back of hand) 	large foreign bodies, diameter greater than 50mm	<b>1</b>	<b>1</b>	vertically-falling drops of water (for example, condensation) 		
with the finger 	medium-sized foreign bodies, diameter greater than 12mm	<b>2</b>	<b>2</b>	drops of water falling at up to 15° from the vertical 		
with tools and wires, diameter greater than 2.5mm 	small foreign bodies, diameter greater than 2.5mm	<b>3</b>	<b>3</b>	spray water falling at up to 60° from the vertical 		
with tools and wires, diameter greater than 1mm 	round foreign bodies, diameter greater than 1mm	<b>4</b>	<b>4</b>	projected water from all directions (limited ingress permitted) 		
limited protection 	dust deposits (limited ingress; no harmful deposits)	<b>5</b>	<b>5</b>	jets of water (limited ingress permitted) 		
complete protection 	entry of dust	<b>6</b>	<b>6</b>	heavy streaming water 		
<p><b>The IP classification is shown as two figures.</b> <b>Example: IP 21</b></p> <p><b>The first figure indicates:</b></p> <p>Protection against touch with the finger and solid bodies with a diameter greater than 12mm. <span style="border: 1px solid black; padding: 2px 10px;">2</span></p> <p><b>The second figure indicates:</b></p> <p>The equipment is protected against vertically falling drops of water. <span style="border: 1px solid black; padding: 2px 10px;">1</span></p> <p style="text-align: center;"><b>IP</b> <span style="border: 1px solid black; padding: 2px 10px;">2</span> <span style="border: 1px solid black; padding: 2px 10px;">1</span></p>				<b>7</b>	short-term immersion 	Protection Summary
				<b>8</b>	immersion 	





# HENIKWON CORPORATION

ONLY ONE SCM BUSDUCT SYSTEM

( Co. No. 161535-W )

Lot 16, Jalan Teknologi, Selangor Science Park 1, Kota Damansara,  
47810 Petaling Jaya, Selangor, Malaysia.

Tel : +603-6140 8000

Fax : +603-6140 8509 / 8510

Email : [info@henikwon.com](mailto:info@henikwon.com)

Web-site : [www.henikwon.com](http://www.henikwon.com)



Certificate No: SG0801875

Certificate No: MY0800095

Certificate No: SG0801940