



sourceco.
globalsolutionswithconfidence

2016

LV Series Busduct



**Reliable - Efficient - Cost-Effective
Electrical Distribution System**

GB/T
27922

ISO
9001

ISO
14001

OHSAS
18001

SA
8000

CE

CCC

RoHS

KEMA

Phone +61 7 5564 6000 Mobile +61 404 295 495 Fax +61 5564 6638
Email martin.evans@sourceco.com



Content

1. System Overview
2. Product features
3. Features—Ease of installation and safe operation
4. High quality guaranteed by state-of-the-art equipments and processes
5. Standards and certificates
6. Electrical specification
7. Physical Data
8. Fittings
9. Installation

System overview



LV[®] series busway system is a reliable and efficient electrical distribution system with sandwich construction and superior performance. It is a safe and robust power distribution system with high electrical efficiency, low voltage drop, high mechanical strength.



The system offers a full line of busway to meet the world market: suitable for three-phase three-wire, three-phase four-wire, three-phase five-wire power supply and distribution, with rated current from 250A to 4000A (for aluminium conductor) & 400A to 6300A (for copper conductor), rated operation voltage up to 690V (rated insulation voltage up to 1000V), IP degree up to IP66 and the frequency 50~60Hz.



Constructed with two-piece of aluminum housing, LV[®] breaks the barrier of weight as one of the lightest system in the business and offers you maximum flexibility. The full aluminum alloy housing, a low magnetic material, avoids hysteresis loss on the distribution system.

LV[®] series busway system is an ideal choice for various applications including commercial, industrial electrical distribution and other verticals.



From every aspect—performance, flexibility, quality and customer value, LV[®] is a superior choice for your next installation.

System overview

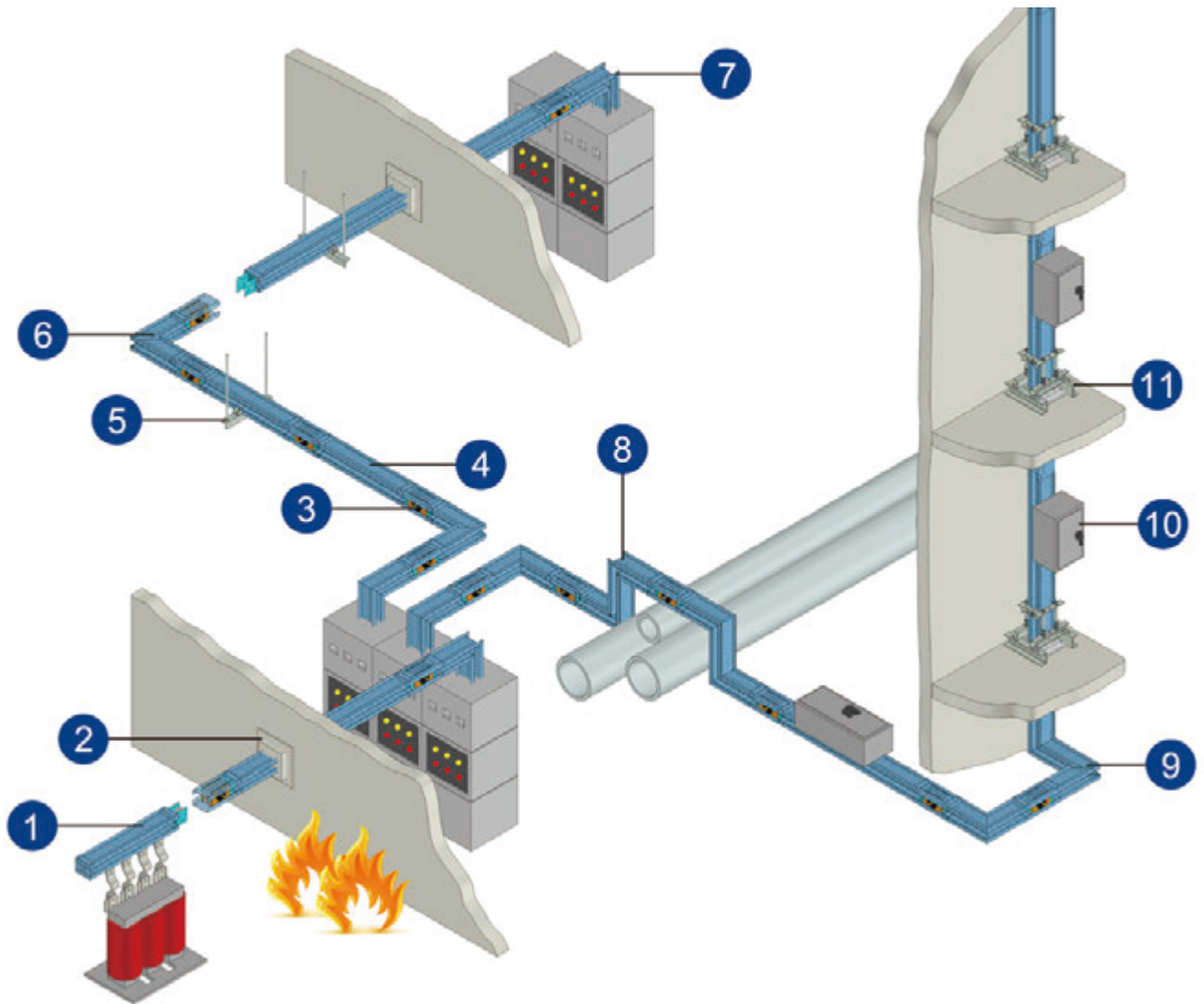

1. Transformer Connection Unit
2. Wall Flange
3. Joint
4. Straight Length
5. Hanger
6. Flatwise Elbow

7. Edgewise Elbow
8. Edgewise Offset
9. Nonstandard Elbow
10. Plug-in Box
11. Spring Hanger

Product Features

—Superior design and performance.

Unique structure design



The unique “serrated surface” design of housing greatly improves the heat dissipation for the whole busway system.

By the design of two-piece housing, LV[®] series busway provides more reliable IP protection for the field application than traditional design.

Novel conductor structure

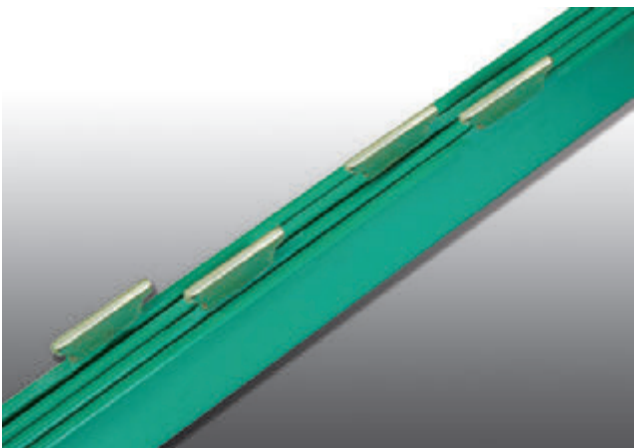

True sandwich structure for the design and construction. Bus bars for plug in length are welded in place by state-of-the-art welding processes. Bus tabs, arranged compactly without bending, achieve the performance of superior heat dissipation, lower temperature rise and elimination of “chimney effect”.

Product Features

—Superior design and performance.

Superior & reliable insulation

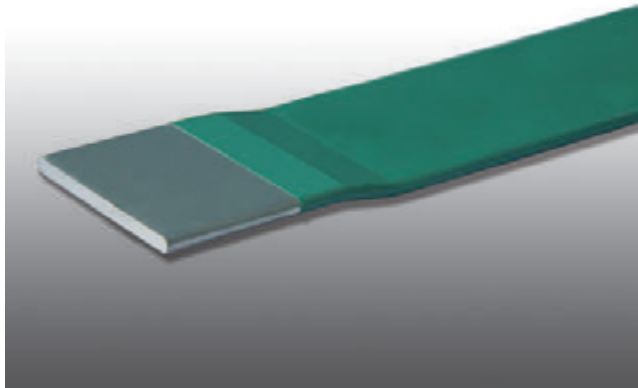

Both Class B and Class F insulation are available with the option of PET and Epoxy insulation. Epoxy on bus bar is applied by an automated process.

Epoxy insulation offers an exceptional electrical performance and superior mechanical strength as well.

The busway system is halogen-free with no toxic emission in case of fire.

Compact design



The dimension of LV busway begins at 125mmx103mm for 400-630A ratings with very compact design. Bus plug is also compact and dimension begins at 360mmx250mmx255 mm for 100A, giving more space for other equipment.

Features

—Ease of installation and safe operation

Safe plug-in operation mechanism



The installation of bus plug can be easily achieved by an ordinary wrench to complete the push in and pull out.

The interlock mechanism is designed in compliance with IEC60439-2, preventing on-load connection and fully insuring the safety of the operator.

Unique error-proof device

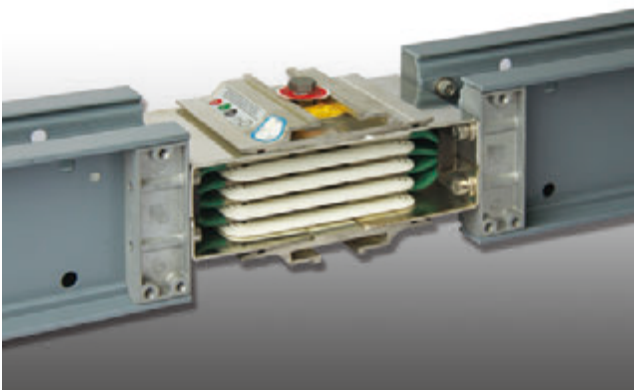

A unique error-proof device is designed to prevent potential damage on bus bar due to incorrect connection.

With this unique device, the installers can not connect two sections of busway successfully with incorrect phase orientation.

Features

—Ease of installation and safe operation

Unique joint design



- Single-bolt-joint design is applied to shorten the time of connection by 50% than the traditional design.
- Double headed "break off" joint bolt is applied to tighten the busway with no torque wrench required. Just a common 16mm socket wrench is used to fasten the fixed captive torque bolt with red indication disc. Belleville spring washers are adopted to ensure pressure evenly applied across the joint.



- Joint insulator with a convex-concave groove edge provides an increased creepage distance.
- Color-coded-temperature indicator applied at busway joint is to give an early warning when high temperature occurs at the joint.

High quality guaranteed by state-of-the-art equipments and processes



High-speed sawing machine, imported from Germany, Numerical control machinery are used to saw and polish busbar ends.

As a result, it gives high quality bus end at the most critical interconnection joint locations without the issue like the deformed, stretched, inconsistent flat end, surfaces which is common with the busbar by the punching process.



Robotic for bus bar welding provides a high quality welding, more precise and stable than the manual process.

High quality guaranteed by state-of-the-art equipments & processes



The state-of-the-art automatic assembly line, guarantees a stable quality and fast delivery. One section of busway feeder can be completed within 90 seconds.



LV® busway demonstrates its excellence also in careful selection of materials, some of which imported from Canada, USA, Austria.

Copper bar manufacturing with high quality of electrolytic copper raw material by purity up to

99.9935%.

Standards and certificates

Reference Standards LV busway system complies with:

IEC 60947.2-1997

IEC 60439.1-2004

IEC 60439.2-2000

IEC 60529

JB/T9662-1999

Certificates

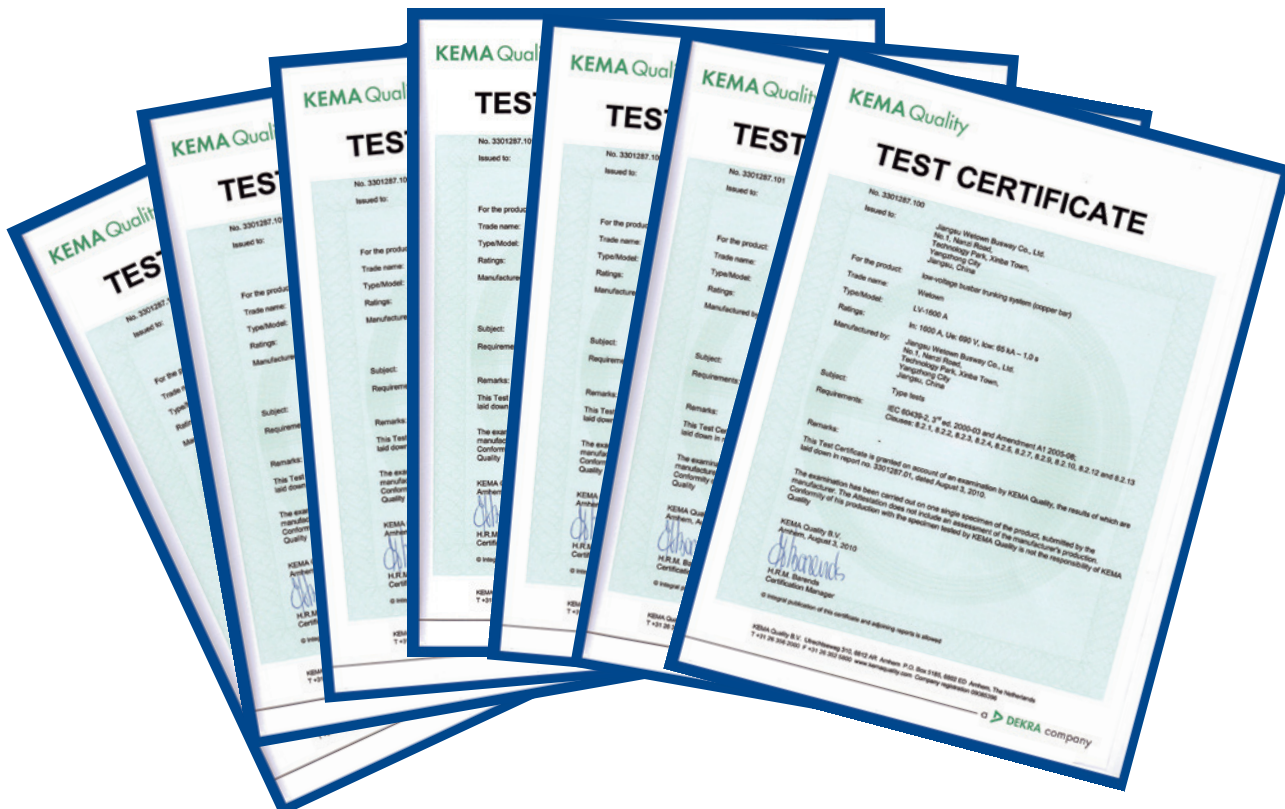

Electrical specification

Aluminum alloy housing of LV® Series Busway provides an extremely low impedance ground path with small resistance for both copper and aluminum systems. plug-in outlet grounding is supplied with tin-plated copper tabs bolted to the plug in box housing for superior continuity through standard bus plug ground stabs.

Grounding resistance of LV busway system (temperature=20°C):

LVC Table 10-1

Current	Internal 50% ground bus resistance($\mu\Omega/m$)	Integrated housing ground DC resistance($\mu\Omega/m$)
400	197.4	22.88
630	148.1	22.88
800	107.7	21.60
1000	91.1	20.83
1250	66.6	19.19
1600	47.4	17.16
2000	37.3	15.60
2500	28.3	13.76
3200	24.9	9.14
4000	18.6	8.12
5000	14.2	7.13
6300	11.0	5.20

LVA Table 10-2

Current	Internal 50% ground bus resistance($\mu\Omega/m$)	Integrated housing ground DC resistance($\mu\Omega/m$)
250	291.7	22.88
400	233.3	22.01
630	179.5	20.83
800	147.7	19.84
1000	112.2	18.29
1250	83.9	16.48
1600	61.7	14.44
2000	56.1	9.59
2500	42.0	8.60
3200	30.9	7.50
4000	25.5	6.80

Electrical specification

Short-circuit ratings

LV busway provides a stable and efficient power transmission, with a high short-circuit withstand capability.

LV busway has been certified by KEMA to be in compliance with IEC60439-1 and-2 short circuit withstand test for 1 second.

Copper conductor

Table 11-1

Current	Rated short circuit withstand current(ICW)KA	Rated peak withstand current(IPK)KA
400	30	63
630		
800		
1000	50	105
1250		
1600		
2000	65	143
2500		
3200		
4000	120	264
5000		
6300		

Aluminum conductor

Table 11-2

Current	Rated short circuit withstand current(ICW)KA	Rated peak withstand current(IPK)KA
250	20	40
400		
630	30	63
800		
1000	50	105
1250		
1600	65	143
2000		
2500	80	176
3200		
4000	120	264

Electrical specification

Resistance, reactance, impedance and voltage drop

Copper busway (50HZ Temperature = 20°C)

Table 12-1

Current	Resistance/ (mΩ/m)	Reactance/ (mΩ/m)	Impedance/ (mΩ/m)	Voltage drop per meter(V)				
				Power factor cosφ				
				0.6	0.7	0.8	0.9	1
400	0.088	0.037	0.118	0.057	0.061	0.064	0.066	0.061
630	0.088	0.037	0.118	0.090	0.096	0.101	0.104	0.095
800	0.064	0.032	0.084	0.088	0.093	0.097	0.099	0.088
1000	0.054	0.026	0.075	0.092	0.097	0.102	0.104	0.093
1250	0.039	0.019	0.053	0.085	0.089	0.093	0.095	0.085
1600	0.028	0.015	0.037	0.080	0.084	0.087	0.088	0.078
2000	0.022	0.012	0.031	0.080	0.084	0.087	0.087	0.076
2500	0.017	0.011	0.025	0.083	0.086	0.087	0.087	0.073
3200	0.015	0.006	0.025	0.074	0.079	0.084	0.087	0.082
4000	0.011	0.003	0.015	0.060	0.066	0.072	0.076	0.076
5000	0.008	0.002	0.011	0.058	0.064	0.069	0.073	0.073
6300	0.007	0.001	0.007	0.051	0.058	0.063	0.069	0.071

Aluminum busway (50HZ Temperature = 20°C)

Table 12-2

Current	Resistance/ (mΩ/m)	Reactance/ (mΩ/m)	Impedance/ (mΩ/m)	Voltage drop per meter(V)				
				Power factor cosφ				
				0.6	0.7	0.8	0.9	1
250	0.146	0.028	0.171	0.048	0.053	0.058	0.062	0.063
400	0.116	0.026	0.152	0.063	0.069	0.075	0.080	0.080
630	0.093	0.024	0.131	0.082	0.090	0.097	0.103	0.101
800	0.077	0.021	0.108	0.087	0.095	0.102	0.108	0.106
1000	0.058	0.018	0.086	0.085	0.093	0.099	0.104	0.101
1250	0.044	0.015	0.062	0.082	0.089	0.095	0.099	0.094
1600	0.032	0.012	0.049	0.080	0.086	0.091	0.094	0.089
2000	0.029	0.011	0.045	0.091	0.098	0.103	0.107	0.100
2500	0.022	0.008	0.031	0.084	0.091	0.096	0.100	0.094
3200	0.016	0.005	0.024	0.075	0.082	0.088	0.092	0.089
4000	0.013	0.003	0.015	0.069	0.076	0.083	0.088	0.088

Electrical specification

Resistance, reactance, impedance and voltage drop

Copper busway (50HZ Temperature = 95°C)

Table 13-1

Current (A)	Resistance/ (mΩ/m)	Reactance/ (mΩ/m)	Impedance/ (mΩ/m)	Voltage drop per meter(V)				
				Power factor cosφ				
				0.6	0.7	0.8	0.9	1
400	0.116	0.037	0.118	0.069	0.075	0.080	0.084	0.081
630	0.116	0.037	0.118	0.109	0.118	0.126	0.132	0.127
800	0.085	0.032	0.084	0.106	0.114	0.121	0.125	0.117
1000	0.072	0.026	0.075	0.111	0.119	0.126	0.131	0.124
1250	0.052	0.019	0.053	0.101	0.109	0.116	0.120	0.113
1600	0.037	0.015	0.037	0.095	0.102	0.107	0.111	0.103
2000	0.029	0.012	0.031	0.095	0.102	0.107	0.110	0.102
2500	0.022	0.011	0.025	0.097	0.103	0.107	0.108	0.097
3200	0.020	0.006	0.025	0.090	0.098	0.105	0.111	0.109
4000	0.015	0.003	0.015	0.075	0.084	0.092	0.099	0.102
5000	0.011	0.002	0.011	0.072	0.081	0.088	0.095	0.097
6300	0.009	0.001	0.007	0.066	0.074	0.082	0.090	0.095

Aluminum busway (50HZ Temperature = 95°C)

Current (A)	Resistance/ (mΩ/m)	Reactance/ (mΩ/m)	Impedance/ (mΩ/m)	Voltage drop per meter(V)				
				Power factor cosφ				
				0.6	0.7	0.8	0.9	1
250	0.188	0.028	0.171	0.058	0.065	0.072	0.078	0.081
400	0.150	0.026	0.152	0.077	0.086	0.094	0.101	0.104
630	0.115	0.024	0.131	0.086	0.107	0.116	0.125	0.126
800	0.061	0.021	0.108	0.074	0.080	0.085	0.088	0.084
1000	0.046	0.018	0.086	0.073	0.078	0.083	0.085	0.080
1250	0.034	0.015	0.062	0.071	0.075	0.079	0.081	0.075
1600	0.025	0.012	0.049	0.069	0.073	0.076	0.078	0.070
2000	0.023	0.011	0.045	0.078	0.083	0.087	0.088	0.080
2500	0.017	0.008	0.031	0.072	0.077	0.080	0.082	0.075
3200	0.013	0.005	0.024	0.064	0.069	0.073	0.075	0.070
4000	0.010	0.003	0.015	0.058	0.064	0.068	0.072	0.070

Physical data

Straight length

Feeder, the straight length without outlets, can be installed either horizontally or vertically.

The standard length is either 3000mm or 4000mm.

The minimum length is 460mm.

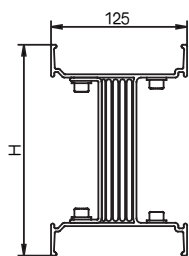

Single-deck
LVA-02~06
LVC-04~25

Fig 14-1

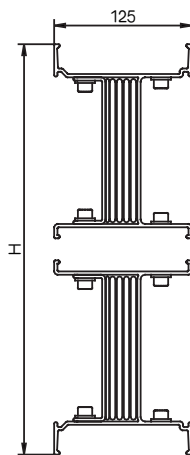

Dual-deck
LVA-20~40
LVC-32~50

Fig 14-2

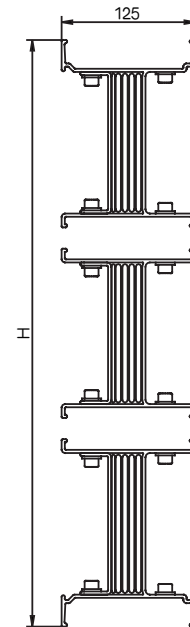

Tripple-deck
LVC-63

Fig 14-3

Copper conductor

Table 14-1

Current	Dimension		Weight per meter (kg/m)		Fig.	
	Width (W)	Height (H)	4wire 100%N	5wire 100%N, 50%PE		
400	125	103	11.8	12.9	14-1	
630		118	14.7	16.2		
800		128	16.6	18.4		
1000		153	21.3	23.7		
1600		188	28.3	31.6		
2000		223	34.9	39.1		
2500		273	44.6	50.2		
3200		352	53.3	59.6		
4000		432	68.8	77.3		14-2
5000		532	88.2	99.4		14-3
6300	701	114.5	128.9			

Aluminum conductor

Table 14-2

Current	Dimension		Weight per meter (kg/m)		Fig.	
	Width (W)	Height (H)	4wire 100%N	5wire 100%N, 50%PE		
250	125	103	6.7	7.1	14-1	
400		113	7.4	7.8		
630		128	8.4	8.9		
800		143	9.4	10.0		
1000		168	11.1	11.9		
1250		203	13.5	14.6		
1600		253	16.9	18.3		
2000		322	21.2	22.8		
2500		392	26.0	28.1		14-2
3200		492	32.8	35.7		
4000	572	39.2	42.9			

Fittings

Plug-in straight length

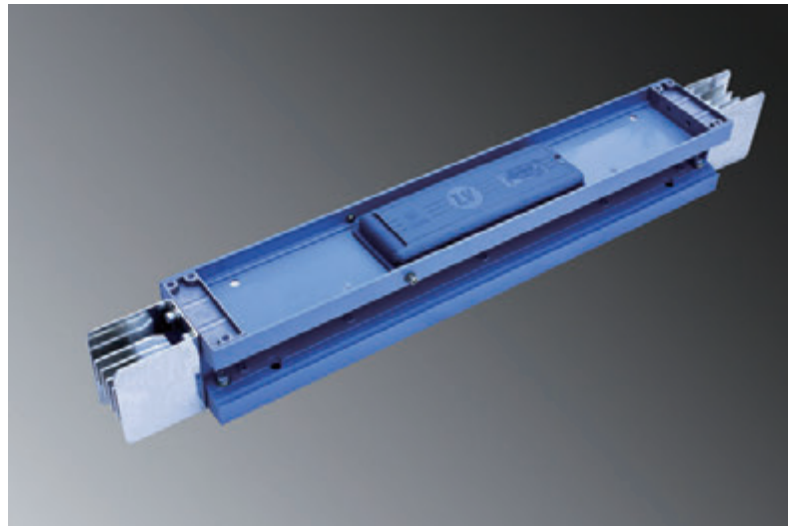

The plug-in busway has a flexible design with optional plug outlets on both sides. A maximum of 5 outlets can be fixed on each side of 3m standard length. The customer may reserve plug outlets for extension in the future when changes occur in terms of the equipment load or busway run. Both base plate and socket cover are set for each plug outlet. Base plate helps to prevent fingers from contacting live conductors (IP2X) by accident, on which the phase sequences of conductors are identified. Socket cover prevents the conductive contacting surface from being contaminated. A pad may be used to keep off dust or moisture.

Standard length is 3000mm or 4000mm. The minimum length is 720mm. The minimum length of L1 (distance from the center of plug outlet to standard end) is 360mm. The minimum length of L2 (distance between the centers of two adjacent plug outlets) is 570mm.

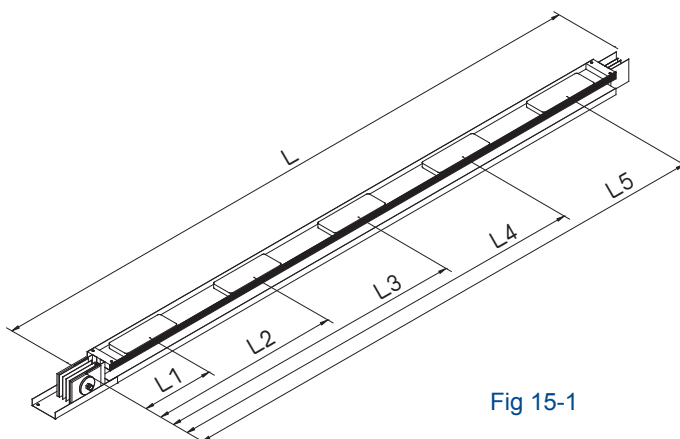

Fig 15-1

- L1=0.36
- L2=0.93
- L3=1.50
- L4=2.07
- L5=2.64

Standard length:

LVC: L=1、2、3m LVA: L=1、2、3m

Optional length:

LVC: L=0.72~2.99m LVA: L=0.72~4m

Fittings

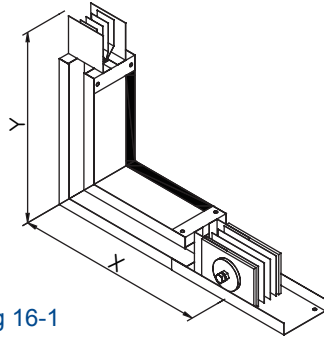

Fig 16-1

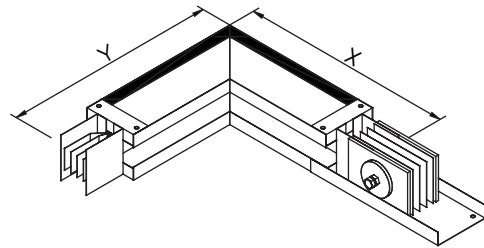

Fig 16-2

L flatwise elbow

Table 16-1

Rated current (A)	Copper busway size (mm)				Aluminium busway size (mm)			
	Minium		Standard		Minium		Standard	
	X	Y	X	Y	X	Y	X	Y
250					341	341	450	450
400	341	341	400	400	351	351	450	450
630	341	341	400	400	366	366	450	450
800	351	351	400	400	381	381	450	450
1000	366	366	400	400	406	406	450	450
1250	391	391	400	400	441	441	500	500
1600	421	421	550	550	491	491	500	500
2000	461	461	550	550	560	560	850	850
2500	511	511	550	550	630	630	850	850
3200	590	590	800	800	730	730	850	850
4000	670	670	800	800	810	810	850	850
5000	770	770	800	800				
6300	939	939	950	950				

L edgewise elbow

Table 16-2

Rated current (A)	Copper busway size (mm)				Aluminium busway size (mm)			
	Minium		Standard		Minium		Standard	
	X	Y	X	Y	X	Y	X	Y
250					363	363	400	400
400	363	363	400	400	363	363	400	400
630	363	363	400	400	363	363	400	400
800	363	363	400	400	363	363	400	400
1000	363	363	400	400	363	363	400	400
1250	363	363	400	400	363	363	400	400
1600	363	363	400	400	363	363	400	400
2000	363	363	400	400	363	363	400	400
2500	363	363	400	400	363	363	400	400
3200	363	363	400	400	363	363	400	400
4000	363	363	400	400	363	363	400	400
5000	363	363	400	400				
6300	363	363	400	400				

Fittings

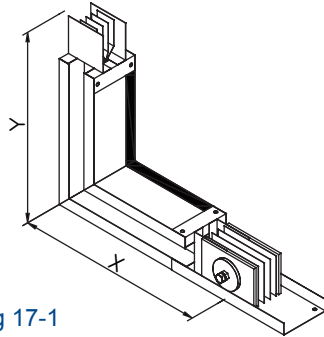

Fig 17-1

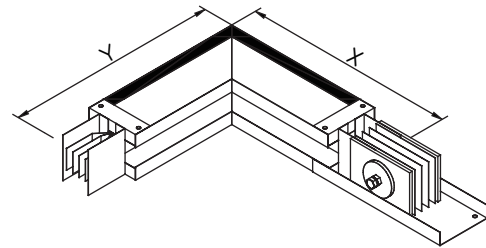

Fig 17-2

L flatwise elbow

Table 17-1

Rated current (A)	Copper busway size (mm)				Aluminium busway size (mm)			
	Minium		Standard		Minium		Standard	
	X	Y	X	Y	X	Y	X	Y
250					341	341	450	450
400	341	341	400	400	351	351	450	450
630	341	341	400	400	366	366	450	450
800	351	351	400	400	381	381	450	450
1000	366	366	400	400	406	406	450	450
1250	391	391	400	400	441	441	500	500
1600	421	421	550	550	491	491	500	500
2000	461	461	550	550	560	560	850	850
2500	511	511	550	550	630	630	850	850
3200	590	590	800	800	730	730	850	850
4000	670	670	800	800	810	810	850	850
5000	770	770	800	800				
6300	939	939	950	950				

L edgewise elbow

Table 17-2

Rated current (A)	Copper busway size (mm)				Aluminium busway size (mm)			
	Minium		Standard		Minium		Standard	
	X	Y	X	Y	X	Y	X	Y
250					363	363	400	400
400	363	363	400	400	363	363	400	400
630	363	363	400	400	363	363	400	400
800	363	363	400	400	363	363	400	400
1000	363	363	400	400	363	363	400	400
1250	363	363	400	400	363	363	400	400
1600	363	363	400	400	363	363	400	400
2000	363	363	400	400	363	363	400	400
2500	363	363	400	400	363	363	400	400
3200	363	363	400	400	363	363	400	400
4000	363	363	400	400	363	363	400	400
5000	363	363	400	400				
6300	363	363	400	400				

Fittings

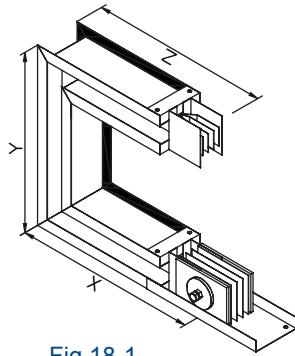

Fig 18-1

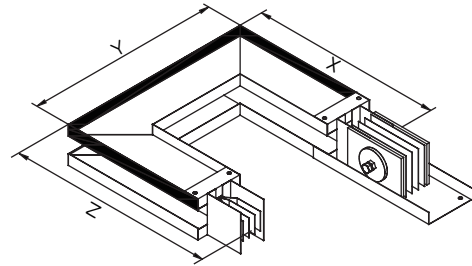

Fig 18-2

Flatwise U

Table 18-1

Rated current (A)	Copper busway size (mm)						Aluminium busway size (mm)					
	Minium			Standard			Minium			Standard		
	X	Y	Z	X	Y	Z	X	Y	Z	X	Y	Z
250							341	326	341	450	500	450
400	341	326	341	400	450	400	351	346	351	450	500	450
630	341	326	341	400	450	400	366	376	366	450	500	450
800	351	346	351	400	450	400	381	406	381	450	500	450
1000	366	376	366	400	450	400	406	456	406	450	500	450
1250	391	426	391	400	450	400	441	526	441	500	650	500
1600	421	486	421	550	700	550	491	626	491	500	650	500
2000	461	566	461	550	700	550	560	764	560	500	650	500
2500	511	666	511	550	700	550	630	904	630	850	1300	850
3200	590	824	590	800	1200	800	730	1104	730	850	1300	850
4000	670	984	670	800	1200	800	810	1264	810	850	1300	850
5000	770	1184	770	800	1200	800						
6300	939	1522	939	950	1550	950						

Edgewise U

Table 18-2

Rated current (A)	Copper busway size (mm)						Aluminium busway size (mm)					
	Minium			Standard			Minium			Standard		
	X	Y	Z	X	Y	Z	X	Y	Z	X	Y	Z
250							363	370	363	400	400	400
400	363	370	363	400	400	400	363	370	363	400	400	400
630	363	370	363	400	400	400	363	370	363	400	400	400
800	363	370	363	400	400	400	363	370	363	400	400	400
1000	363	370	363	400	400	400	363	370	363	400	400	400
1250	363	370	363	400	400	400	363	370	363	400	400	400
1600	363	370	363	400	400	400	363	370	363	400	400	400
2000	363	370	363	400	400	400	363	370	363	400	400	400
2500	363	370	363	400	400	400	363	370	363	400	400	400
3200	363	370	363	400	400	400	363	370	363	400	400	400
4000	363	370	363	400	400	400	363	370	363	400	400	400
5000	363	370	363	400	400	400						
6300	363	370	363	400	400	400						

Fittings

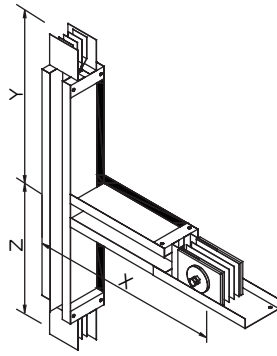

Fig 19-1

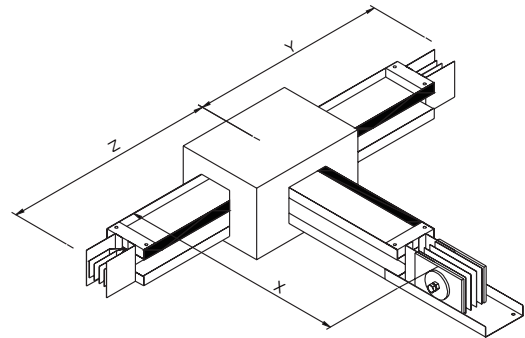

Fig 19-2

Flatwise Tee

Table 19-1

Rated current (A)	Copper busway size (mm)						Aluminium busway size (mm)					
	Minium			Standard			Minium			Standard		
	X	Y	Z	X	Y	Z	X	Y	Z	X	Y	Z
250							341	290	290	450	350	350
400	341	290	290	400	350	350	351	295	295	450	350	350
630	341	290	290	400	350	350	366	302	302	450	350	350
800	351	295	295	400	350	350	381	310	310	450	350	350
1000	366	302	302	400	350	350	406	322	322	450	350	350
1250	391	315	315	400	350	350	441	340	340	500	400	400
1600	421	330	330	550	400	400	491	365	365	500	400	400
2000	461	350	350	550	400	400	560	399	399	850	550	550
2500	511	375	375	550	400	400	630	434	434	850	550	550
3200	590	414	414	800	550	550	730	484	484	850	550	550
4000	670	454	454	800	550	550	810	524	524	850	550	550
5000	770	504	504	800	550	550						
6300	939	589	589	950	600	600						

Edgewise Tee

Table 19-2

Rated current (A)	Copper busway size (mm)						Aluminium busway size (mm)					
	Minium			Standard			Minium			Standard		
	X	Y	Z	X	Y	Z	X	Y	Z	X	Y	Z
250							363	411	411	400	500	500
400	363	411	411	400	500	500	363	421	421	400	500	500
630	363	411	411	400	500	500	363	436	436	400	500	500
800	363	426	426	400	500	500	363	451	451	400	500	500
1000	363	436	436	400	500	500	363	476	476	400	500	500
1250	363	461	461	400	500	500	363	511	511	400	600	600
1600	363	496	496	400	600	600	363	561	561	400	600	600
2000	363	531	531	400	600	600	363	630	630	400	900	900
2500	363	581	581	400	600	600	363	700	700	400	900	900
3200	363	660	660	400	900	900	363	800	800	400	900	900
4000	363	740	740	400	900	900	363	880	880	400	900	900
5000	363	840	840	400	900	900						
6300												

Fittings

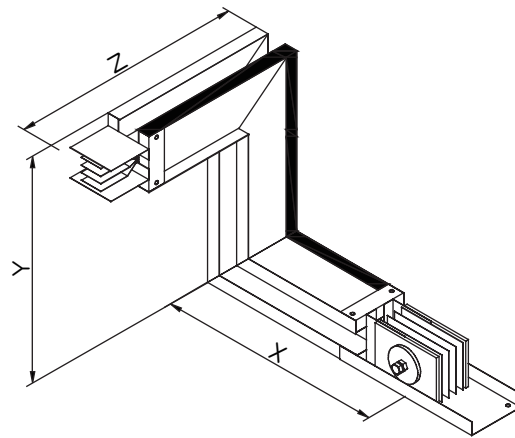

Fig 20-1

Combination Elbow

Table 20-1

Rated current (A)	Copper busway size (mm)						Aluminium busway size (mm)					
	Minium			Standard			Minium			Standard		
	X	Y	Z	X	Y	Z	X	Y	Z	X	Y	Z
250							341	348	363	450	450	400
400	341	348	363	400	400	400	351	358	363	450	450	400
630	341	348	363	400	400	400	366	373	363	450	450	400
800	351	358	363	400	400	400	381	388	363	450	450	400
1000	366	373	363	400	400	400	406	413	363	450	450	400
1250	391	398	363	400	400	400	441	448	363	500	500	400
1600	421	428	363	550	550	400	491	498	363	500	500	400
2000	461	468	363	550	550	400	560	567	363	850	850	400
2500	511	518	363	550	550	400	630	637	363	850	850	400
3200	590	597	363	800	800	400	730	737	363	850	850	400
4000	670	677	363	800	800	400	810	817	363	850	850	400
5000	770	777	363	800	800	400						
6300	939	946	363	950	950	400						

Fittings

Flange end

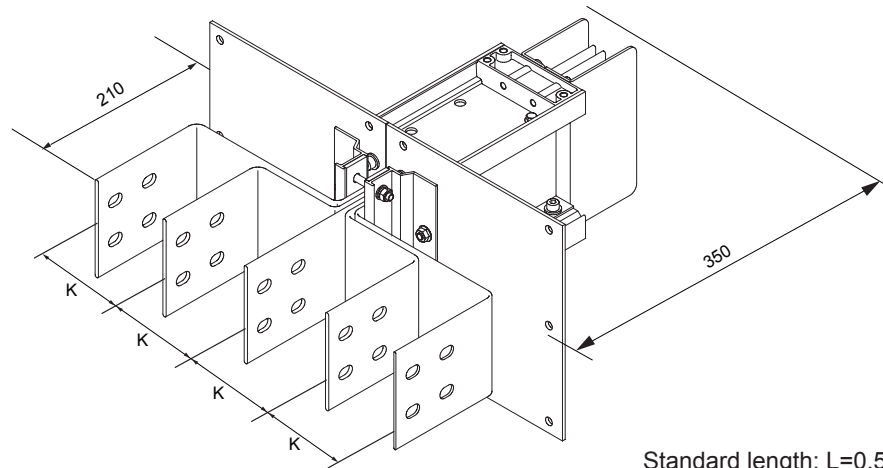

Standard length: L=0.56m

Nonstandard length: L=0.56~2.00m

Fig 21-1

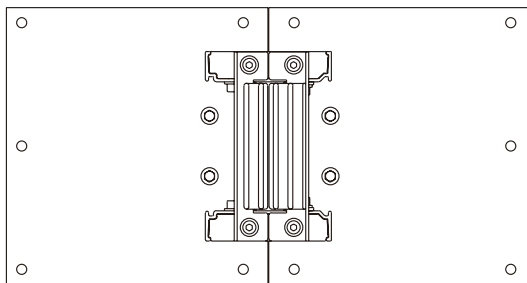

Section view

Fig 21-2

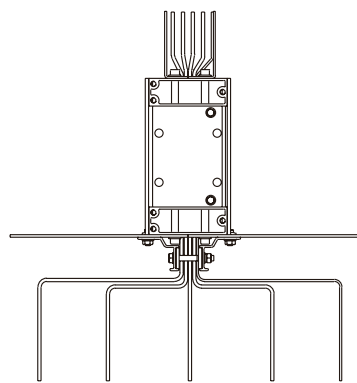

Top view

Fig 21-3

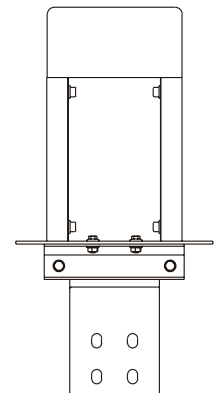

Side view

Fig 21-4

Flanged end and end tap box can be used in connection with any type of switchgear cabinets and transformers. Flanged end busbar spacing can be customized on specific application.

Note:

All the dimensions provided are for standard products. Please contact our engineers for customized dimensions.

Fittings

Flanged end cut out and drilling pattern

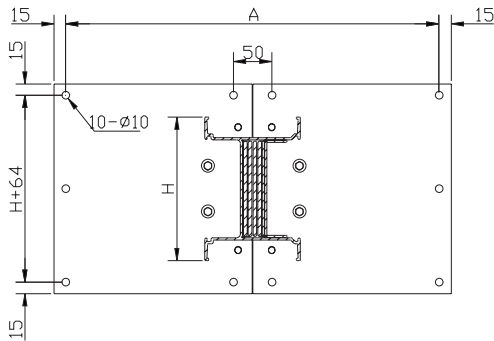

Fig 22-1

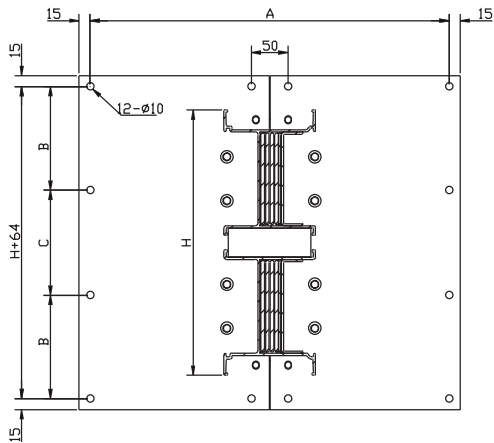

Fig 22-2

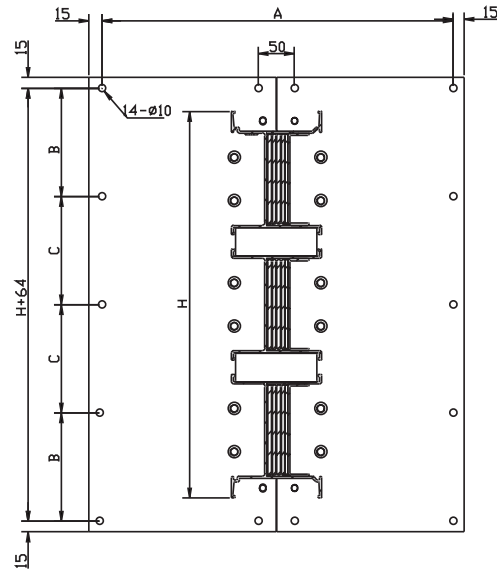

Fig 22-3

LVC

Table 22-1

Rated Current (A)	3L+N+PE Size (mm)				3L+N Size (mm)			Fig
	H	A	B	C	A	B	C	
400	103	490	-	-	370	-	-	22-1
630	103	490	-	-	370	-	-	
800	118	490	-	-	370	-	-	
1000	128	490	-	-	370	-	-	
1250	153	490	-	-	370	-	-	
1600	188	490	-	-	370	-	-	
2000	223	490	-	-	370	-	-	
2500	273	490	-	-	370	-	-	
3200	352	490	140	136	370	140	136	
4000	432	490	165	166	370	165	166	22-2
5000	532	490	200	196	370	200	196	22-3
6300	701	490	190	192.5	370	190	192.5	

LVA

Table 22-2

Rated Current (A)	3L+N+PE Size (mm)				3L+N Size (mm)			Fig
	H	A	B	C	A	B	C	
250	103	490	-	-	370	-	-	22-1
400	113	490	-	-	370	-	-	
630	128	490	-	-	370	-	-	
800	143	490	-	-	370	-	-	
1000	168	490	-	-	370	-	-	
1250	203	490	-	-	370	-	-	
1600	253	490	-	-	370	-	-	
2000	322	490	130	126	370	130	126	
2500	392	490	150	156	370	150	156	
3200	492	490	185	186	370	185	186	22-2
4000	572	490	210	216	370	210	216	

Fittings

Flanged end bar hole pattern

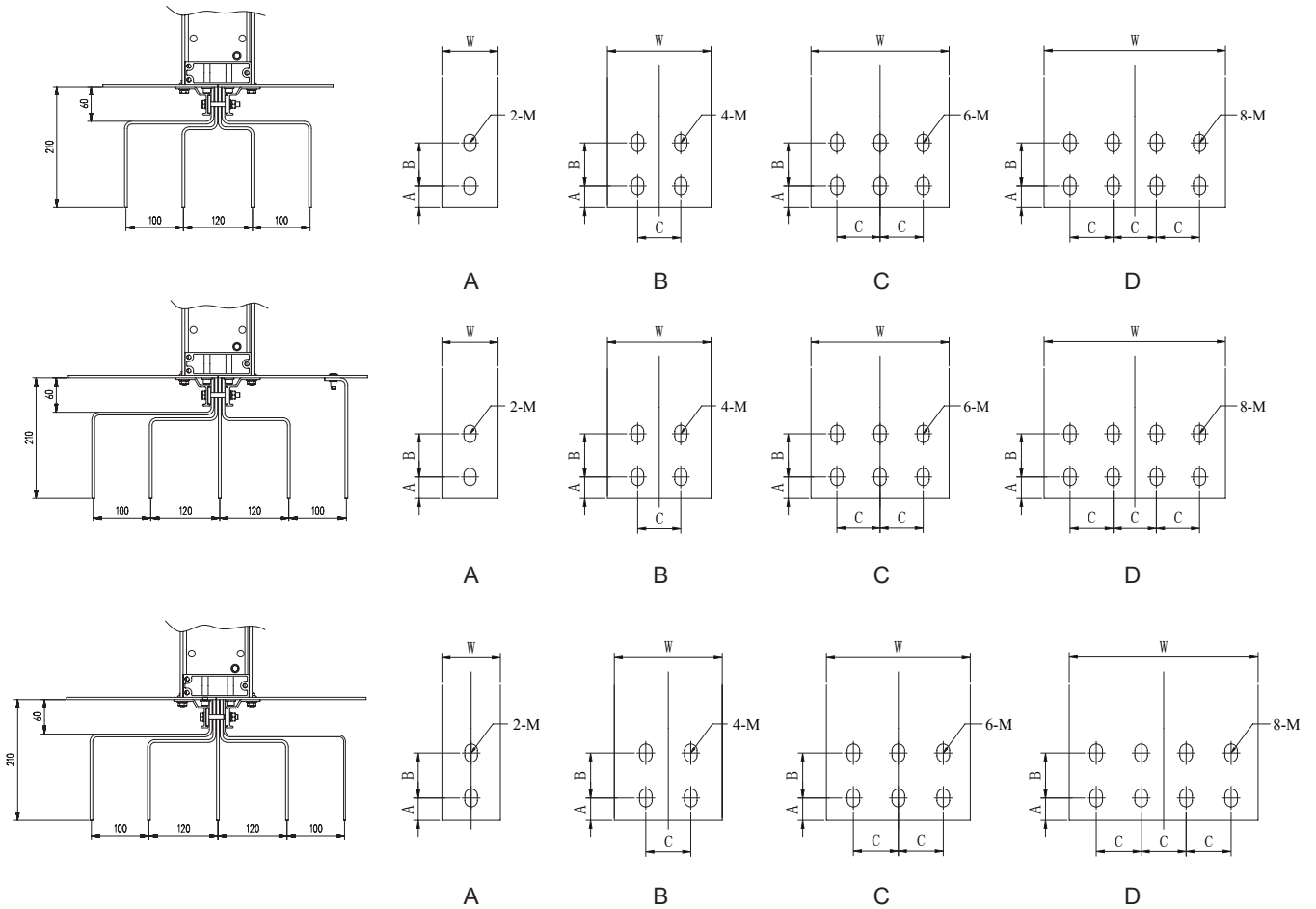

Copper conductor

Table 23-1

Rated Current	A	B	C	M	Type
400	25	50		Φ12	A
630	25	50		Φ14×20	A
800	25	50		Φ14×20	A
1000	25	50		Φ14×20	A
1250	25	50	50	Φ14×20	B
1600	25	50	50	Φ14×20	B
2000	25	50	50	Φ14×20	C
2500	25	50	50	Φ14×20	D
3200	25	50	50	Φ14×20	B
4000	25	50	50	Φ14×20	C
5000	25	50	50	Φ14×20	D
6300	25	50	50	Φ14×20	C

Aluminum conductor

Table 23-2

Rated Current	A	B	C	M	Type
250	25	50		Φ14×20	A
400	25	50		Φ14×20	A
630	25	50		Φ14×20	A
800	25	50		Φ14×20	A
1000	25	50	50	Φ14×20	B
1250	25	50	50	Φ14×20	C
1600	25	50	50	Φ14×20	C
2000	25	50	50	Φ14×20	D
2500	25	50	50	Φ14×20	C
3200	25	50	50	Φ14×20	C
4000	25	50	50	Φ14×20	D

Fittings

Expansion joint

Expansion length is the transition section compensating for thermal expansion, it is normally set each 60m in linear distance.

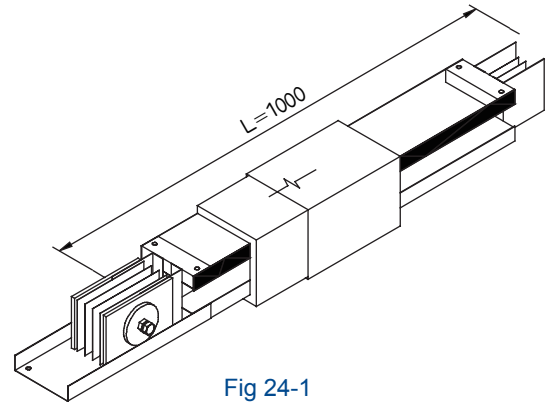

Fig 24-1

Reducer

This reducer section is used for reducing busbar size to the final load, it provides users with more economic power transmission and distribution method.

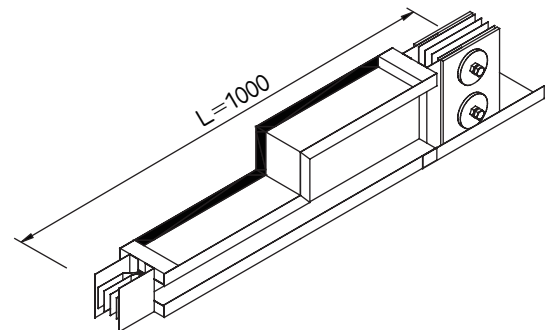

Fig 24-2

Transposition joint

Transposition section is the transition parts used for changing phase sequence of the busbar; its minimum size is 1500mm. The phase sequence of both sides has to be provided by the customer.

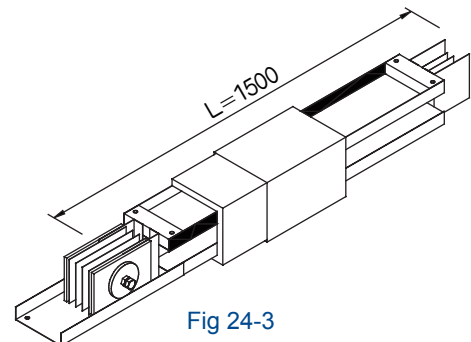

Fig 24-3

Terminal cover

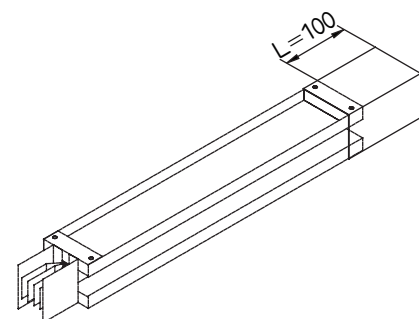

Fig 24-4

Fittings

Bus plug

LV bus plug is adopted to apply electrical power directly to the load from the busway system. Fully considering customer's requirements, LV bus plug offers the options of circuit breaker or fuse.

Bus plug with circuit breaker

- Circuit breaker protection can be available with a current range from 16A-1000A.
- Load protection in the plug can be 3-Pole or 4-Pole circuit breakers, including accessories of breakers such as rotary handles, shunt release, thermal magnetic release and leakage-current protection module.

Plug with fuse

- Plug-boxes with fuses can be produced according to customer specifications.
- Unique fail-safe base pins

the plug is equipped with a positioning device that prevents incorrect phase installations.

plug Pins: All pins are silver-plated to improve the electrical conductivity.

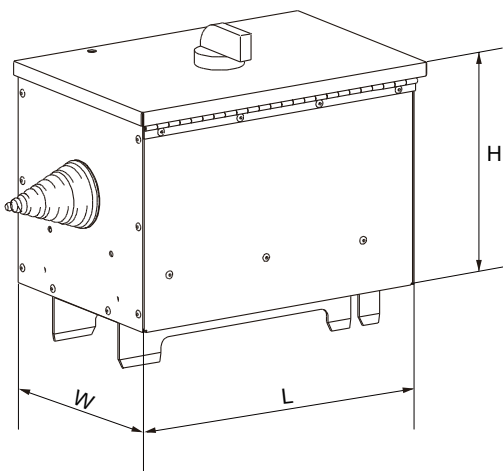

Fig 25-1

Plug-in box Dimensions (L×W×H)mm

- For non-standard dimension, please contact the manufacturer.

Table 25-1

Current ratings (A)	Plug-in box Dimensions		
	L(mm) Length	W(mm) Width	H(mm) Height
100	360	250	250
160	400	250	250
250	520	270	270
400	650	310	310
630	800	340	340
800-1000	1200	420	350

Note:

Table 25-1 size is based on the size of common circuit breaker 3p/4p.

Fittings

End tap box

LV® series busway system tap boxes are used where a run of busway is fed by cable. we offer standard size end tap box (1m×1m×1m) while we also supply with nonstandard box according to the on-site measurement.



Flang end with end tap box connection

The flange plate can be manufactured according to the size of the end tap box, it can be connected directly with end tap box.



Installation

LV busway protection class can be up to IP66 according to different applications.

Notes:

- IP40---"4" indicates that solid objects greater than 1mm in diameter will not penetrate the housing."0" denotes no protection.
- IP42---"4" indicates that solid objects greater than 1mm in diameter will not penetrate the housing."2" denotes prevention of water dripping inside by an angle of up to 15°.
- IP54---"5" for dust, "4" indicates splashes of water.
- IP65---"6" for dust density, "5" indicates protection from water spray.
- IP66---"6" for dust density, "6" for protection of stronger water spray

Minimum clearance required for installation

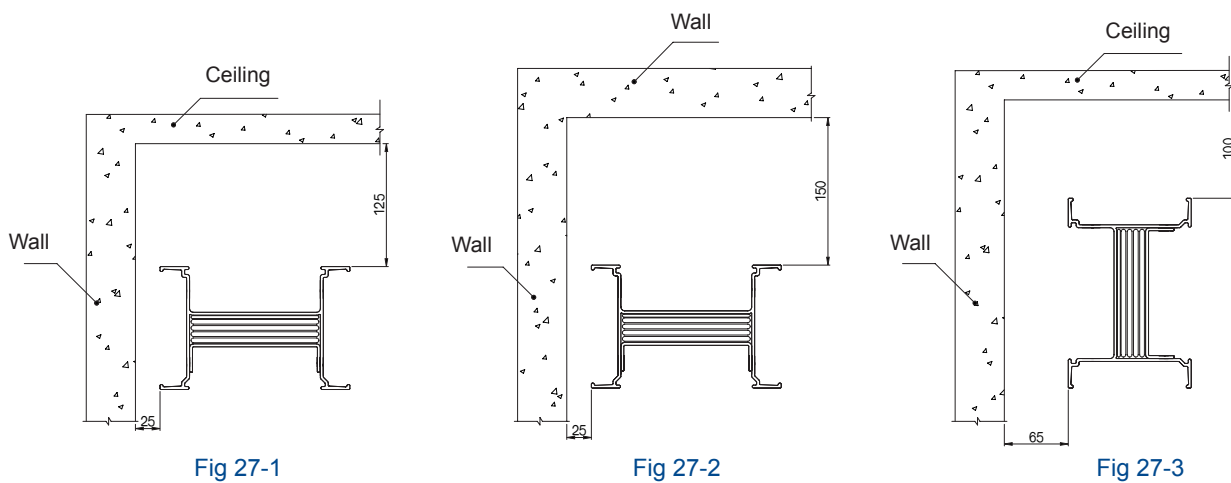

Minimum clearance required for plug-in box installation

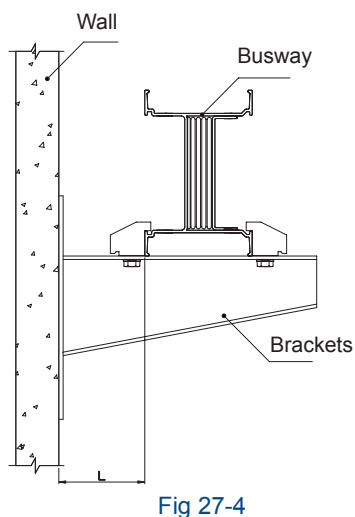

Fig 27-4

Table 27-1

Current level for plug-in box	L(mm)
100	150
160	175
250	195
400	210
630	230
800	260
1000	300

Installation

Horizontal wall-through installation

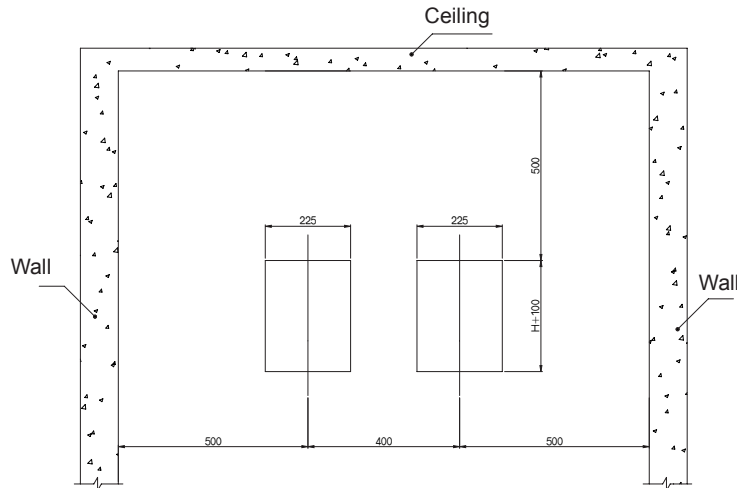

Fig 28-1

Horizontal installation-trapeze hangers Overhead Support

Holes should be first drilled in the floor so as to inlay steel expansion bolts (holes may also be drilled on site for flexible installation) or pre-bury steel U-channel for welding with hangers. The distance between two adjacent hangers shall not exceed 2m. Please specify any special requirements when placing your order.

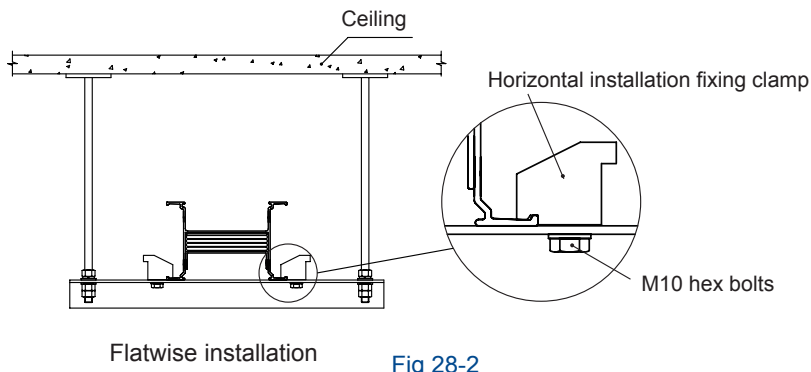

Fig 28-2

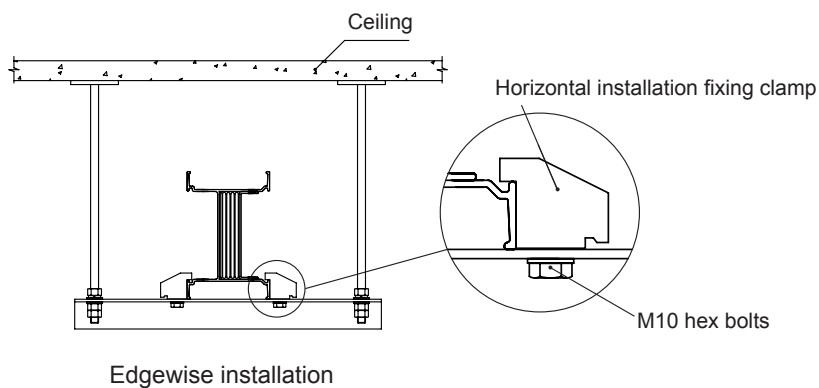

Fig 28-3

Installation

Horizontal installation-wall support

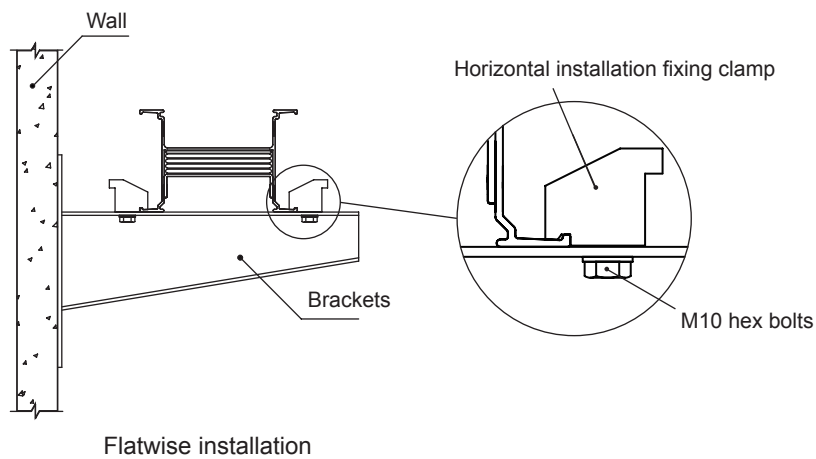

Fig 29-1

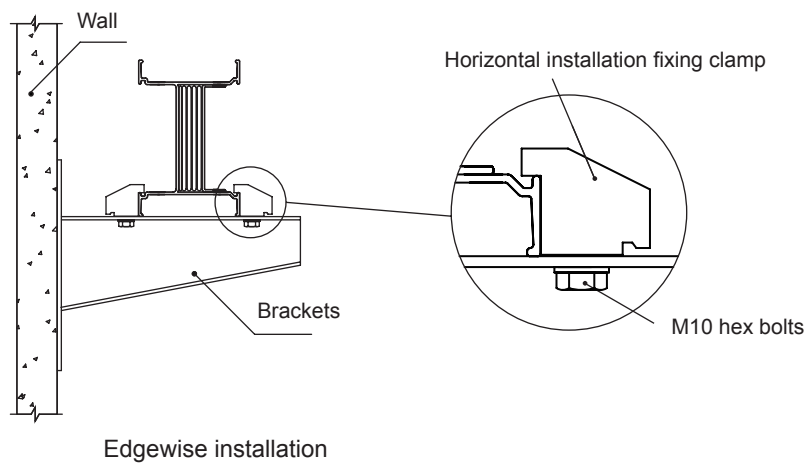

Fig 29-2

Installation

Vertical installation

When installing a vertical bus run, please refer to the figure for the dimension of the access holes. Please ensure that the spacing between every two runs of busway exceeds 350mm, especially if there are two or more vertical runs of busway installed in the same riser. Please refer to the figure below:

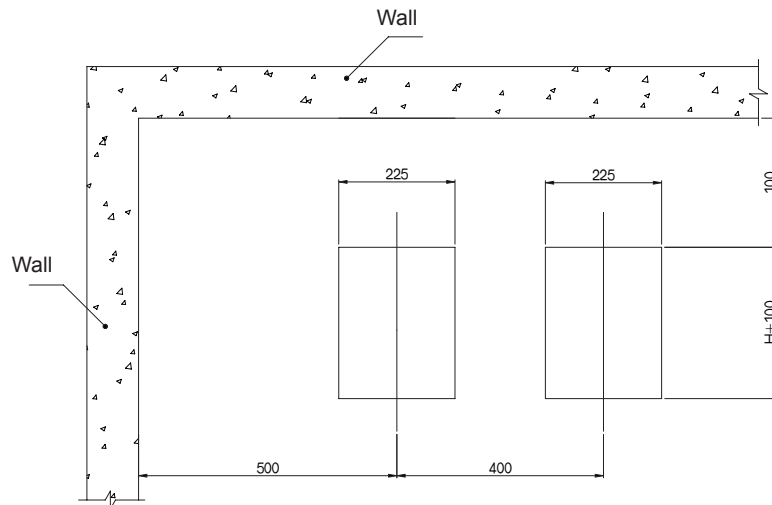
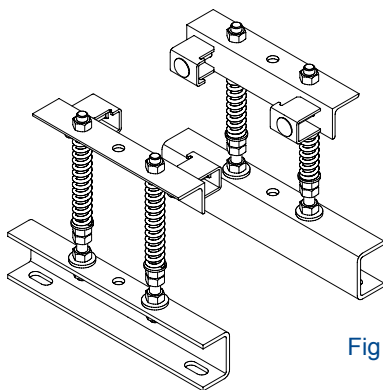

Fig 30-1

Installation for Vertical Spring Hanger



Vertical Spring Hanger

Fig 30-2

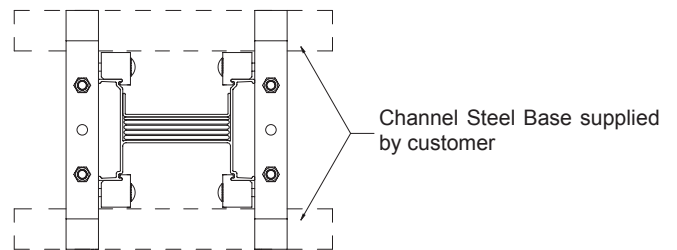

Fig 30-3

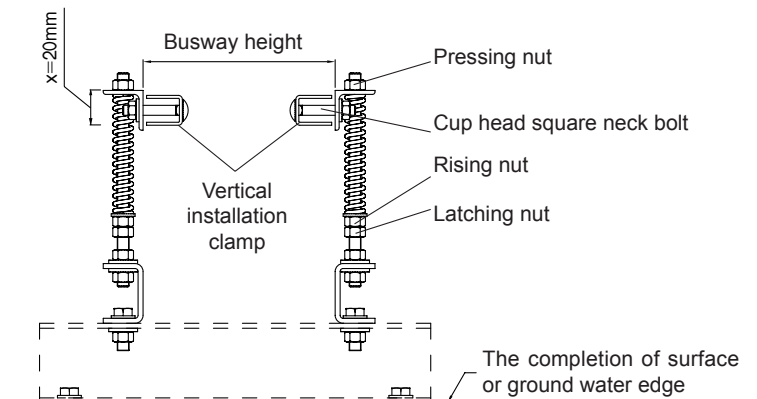

Fig 30-4

Installation Schematic Diagram

Installation

Installation for Vertical Fixed Hanger

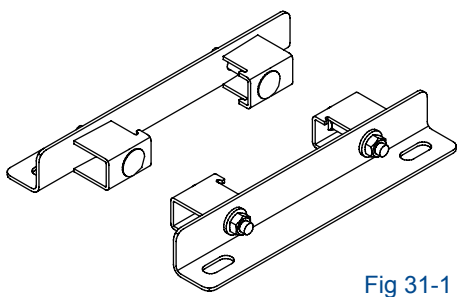

Fig 31-1

Vertical Fixed Hanger

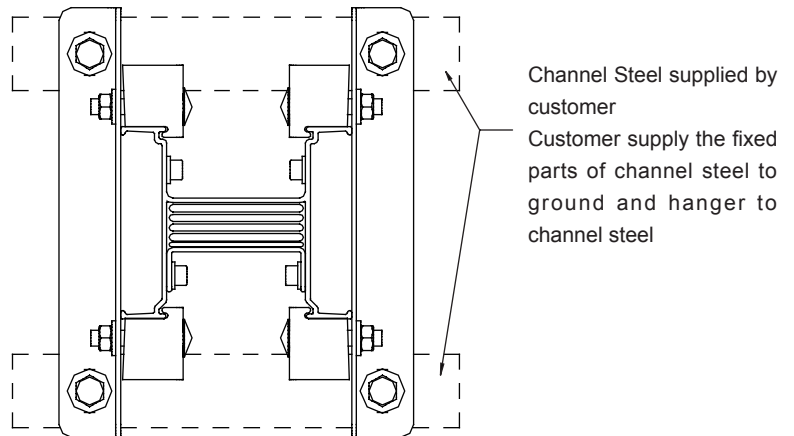
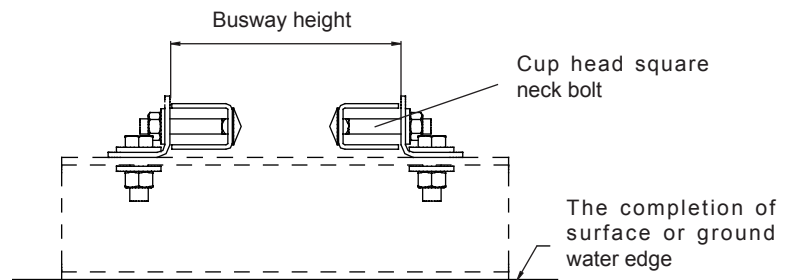

Fig 31-2



Installation Schematic Diagram

Fig 31-3

Notes



Field Drawing Page

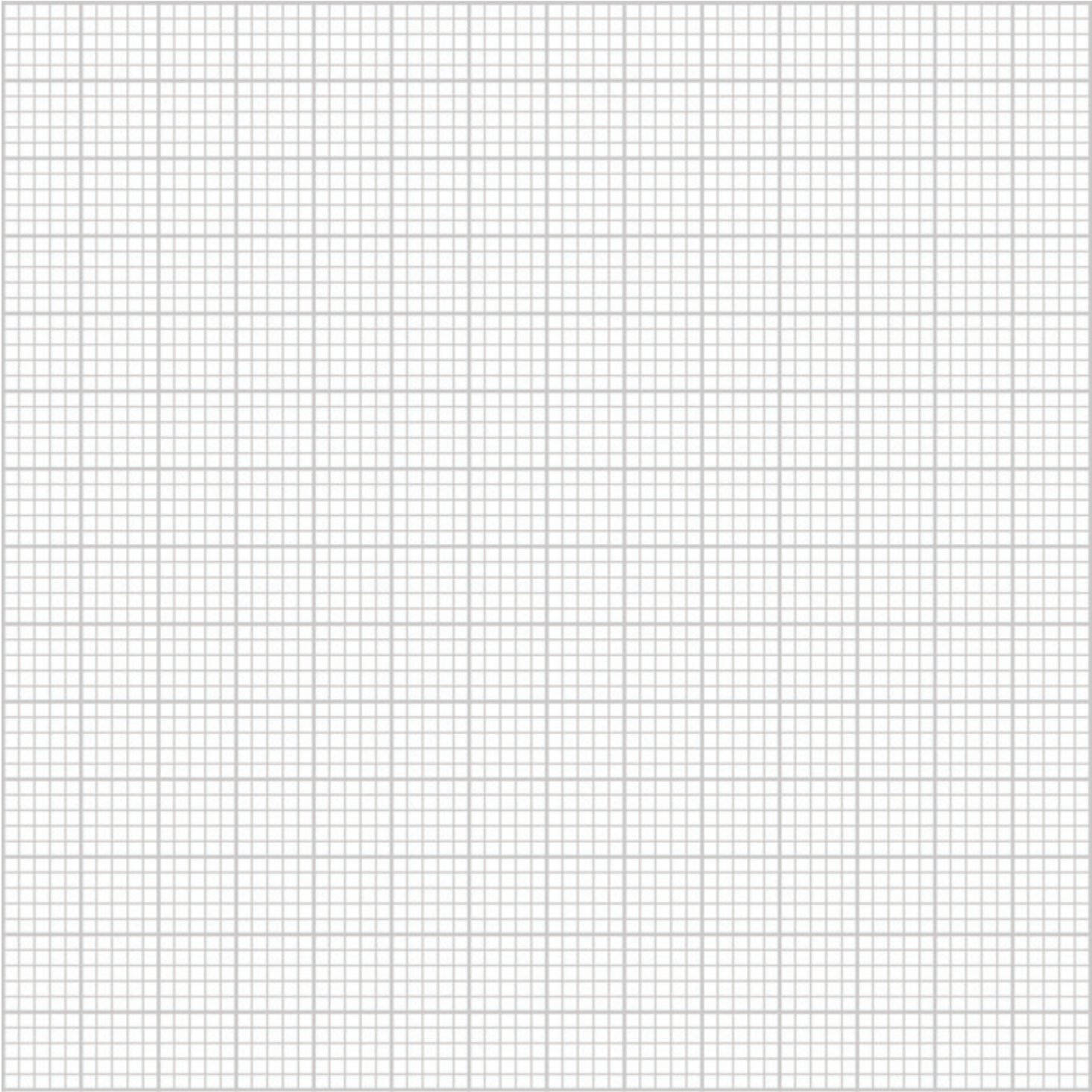



LV Series Busduct



**Reliable - Efficient - Cost-Effective
Electrical Distribution System**

GB/T
27922

ISO
9001

ISO
14001

OHSAS
18001

SA
8000

CE

CCC

RoHS

KEMA