

Insulated Conductor Rail

SingleFlexLine Program 0811

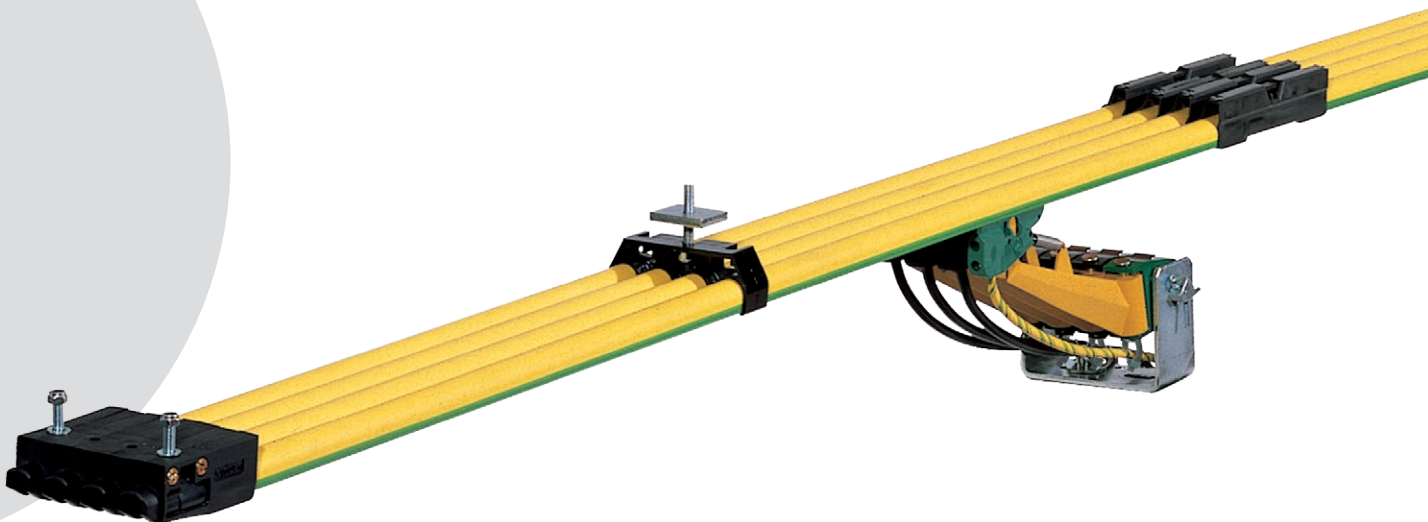

CONDUCTIX
wampfler

Ⓞ DELACHAUX GROUP

Contents

System Description	5
Technical Data	6
System Components and Standards	7
Components and their use	7
Project Planning	9
Technical notes and engineering information	9
Dimensioning the Conductor Rail System	11
Conductor Rail arrangement and curves	11
Using Rail Connectors as Expansion Joints	12
Parts of the Conductor Rail System	14
Insulated Conductor Rails	14
Rail Connectors	14
Curves	15
Power Feeds	16
Anchor Clamps	17
Air Gaps	17
End Caps	18
Cable Lugs	18
Hanger Clamps	19
Installation Examples of Hanger Clamps	20
Pickup Guide, short type	21
Pickup Guide, long type	22
Current Collectors	23
Current Collectors, general description	23
Types of Current Collectors	24
Towing Arm	26
Current Collector Support Bracket	26
Connection Cables	27
Replacement Parts	28
Current Collector Head, 48 mm	28
Current Collector Head, 68 mm	28
Stabilization Springs for Current Collector Head	28
Tools and Assembly Accessories	29
Bending Device	29
Notching Pliers	29
Cutting Pliers	29
Rail Calibration Tool	30
Release Pliers	30
System Layout	31
Conductor Rail Program Summary	33

SingleFlexLine Program 0811

The SingleFlexLine Conductor Rail Program 0811 is used as a standard product in countless applications in the industrial sector. It has the advantages of a high rigidity due to the profile's geometry, and the unique, tool-free connection method with bayonet couplings. By enlarging the notch in the Conductor Rail, every Rail Connector can be used as an Expansion Joint, thus eliminating the need for costly and time-consuming installation of additional Expansion Joints. To match the routing of your rail system, you can use the Bending Device (page 29) to adjust the rails' radii and you can easily adjust the number of poles. This makes the system ideal for electrified monorail systems (EMS), sorter systems, and similar installations. The 0811 system can also be turned into slip ring assemblies for 360 degree rotation.

The 0811 Conductor Rail System is available in a variety of conductor and insulating materials and can be adjusted to meet most general requirements. The plastic insulation of the conductor rails is colored "safety yellow" in accordance with general marking regulations. PE (protective earth) conductor rail components are yellow with green stripe.

Additionally, the 0811 Conductor Rail System is available with the Safety System PE^{plus} (see catalog KAT0800-0002 "Conductor Rails for Electrified Monorail Systems"). The specially designed PE^{plus} protective earth conductor profiles and copper graphite shoes cannot be inadvertently inserted into a phase rail. This safety system is compatible with existing components and can be retrofitted in sections without needing to change the mounting positions of the Conductor Rails or Current Collectors. All connecting components of the PE^{plus} system, e.g. End Caps and Rail Connectors, are colored green.

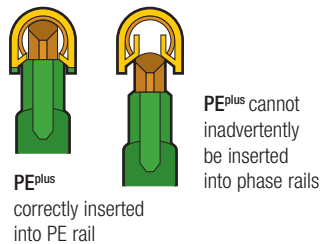

A distinctive feature of the SingleFlexLine 0811 is the easy installation and adaptation of its individual components. Most of the installation can be done without using tools, by simply clipping in or turning in parts. For other operations, simple standard tools can be used. Special installation tools, if needed, can be bought or rented for the duration of the installation.

The SingleFlexLine program is a modular system that can be adjusted to the requirements of energy and data transmissions for mobile consumers. This product is intended for indoor use or weatherproof outdoor use corresponding to protection class IP 23 for Conductor Rails in the field of Electrified Monorail Systems and similar applications. For installation multi-pole Hanger Clamps are available, as well as combination holders for the accommodation of conductor rails, code and barcode tapes, and data transmission lines for contact-free data communication along the routings.

Other applications can be configured with any number of poles, routing characteristics, and mounting positions. Please note that the applicability of our components, due to the multitude of options and variable general and environmental conditions, has to be reviewed case-by-case. An express warranty cannot be given for attributes and functions in applications which differ from intended use and technical data.

The components of a Conductor Rail system are classified as a "partly complete machinery" and are to this extent subject to the machinery directive for use in the european union (MRL 2006/42/EG).

IEC Test Finger

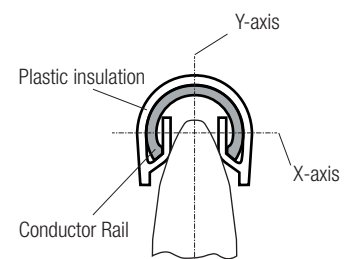
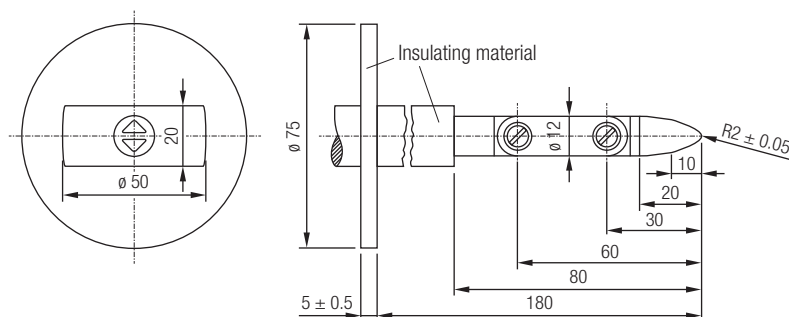

Testing of contact protection with IEC/UL/NEMA jointed test finger (12 mm foreign body)

Technical Data

System	Single pole Conductor Rail System for indoor and weather-protected outdoor use in Electrified Monorail Systems and similar applications
Installation orientation	User-defined – avoid installation with access opening upturned (foreign body ingress + reduced protection type)
System length	4000 mm
Pole spacing	20 mm
Rated suspension spacing	Nom. 400-1000 mm (see table hanger clamps)
System length	Unlimited (depending on power feed concept)
Travel speed	Max. 600 m/min (restrictions for certain components and rail radii)
Rated voltage	Nom. 690 V / 500 V UL (min. voltage 24V / min. current 3A)
Permitted ambient temperature	-10 to +55°C (higher temperatures possible on request / rail insulation), -30°C on request
Max. temperature difference	Δ K 50°C
Max. insulation temperature	Standard (PVC): 85°C, heat-resistant variant (PPE + PS-I): 115°C
Protection type	IP 23 (rail system, Current Collector only when inserted)
Storage temperature	-30 to +40°C; store away from sunlight, avoid condensation
Min. installation temperature	-10°C (recommended installation temperature: above 0°C)
Local approvals	UL / CSA / GOST-R

Specific values			
Conductor material	Hot-dip galvanized steel	Electrolytic copper	Data metal
Type	081112	081116	081118
Current Load at 100% duty cycle and 35 °C (rated value) [A]	32	100	10
DC resistance at + 35°C [Ω / 1000 m]	5.506	0.743	29.313
at + 20°C [Ω / 1000 m]	5.122	0.703	29.200
Impedance at + 35°C [Ω / 1000 m]	5.507	0.750	29.314
Impedance at + 20°C [Ω / 1000 m]	5.124	0.709	29.202
Moment of inertia Ix [cm⁴]	0.024		
Moment of inertia Iy [cm⁴]	0.048		
Modulus of resistance Wx [cm³]	0.048		
Modulus of resistance Wy [cm³]	0.076		

Chemical resistance	
Insulating material	PVC: good general chemical resistance PPE + PS-I: average general chemical resistance, critical when in direct contact with oil
Installation material	PC, PA, PBT: PC, PA, PBT: good general chemical resistance, partly limited
Conductor material	Data metal: good chemical resistance Galvanized steel: limited resistance Copper: limited resistance

Information about chemical resistance are general notes and depend on temperature, exposure time, concentration and interactions, and need to be verified in individual cases. Please contact us before usage in critical environmental conditions such as galvanizing plants, pickling plants, compost works, and locations with high concentrations of chemicals (e.g. solvents, aromates, benzols, etc.) for the purpose of alternative installation positions, materials and possibly necessary additional components.

Insulation cover	
Material	Stabilized hard PVC; safety warning color (RAL 1018) or PPE + PS-I (halogen-free) (RAL 1021)
Dielectric strength	22.4 kV (PVC), 45 kV (PPE + PS-I) as defined by DIN 53481
Leakage current resistance	400 < CTI as defined by IEC 112 / VDE 0303 (PPE + PS-I: 300 < CTI)
Flammability	Meets requirements for insulation materials in UL 94 V-1; Flame retardant and self-extinguishing (IEC 60695-11-10), halogen-free PPE-SB

Note: Some restrictions may apply in combinations of certain requirements

System Components and Standards

Conductor Rail System Components

The modular system SingleFlexLine 0811 is divided into basic components and additional components not necessarily used in all applications.

Basic Components

- ① Conductor Rail
- ② Rail Connectors
- ③ Hanger Clamps
- ④ End Caps
- ⑤ End Cap with Power Feed
- ⑥ Current Collectors

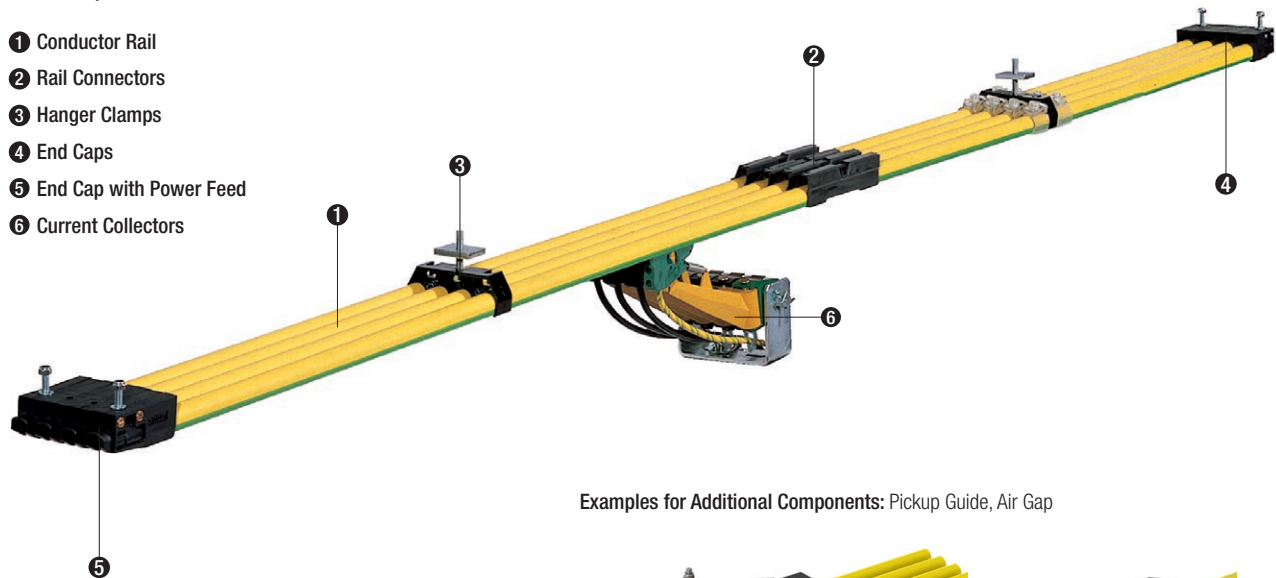

Examples for Additional Components: Pickup Guide, Air Gap

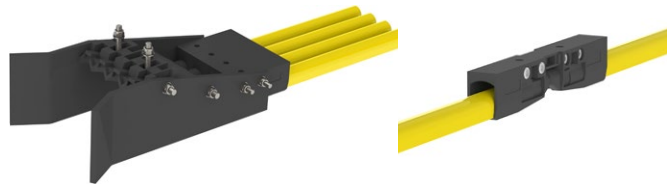

Note

Owing to technical advancements of our products, this catalog cannot list all available variants and additional components. If needed, please contact our sales department.

Relevant Standards

DIN EN 60664-1, VDE 0110-1:2008-1	Insulation coordination for electrical equipment in low-voltage installations - Part 1: Principles, requirements and testing (IEC 60664-1:2007); German edition EN 60664-1:2007
DIN EN 60204-1, VDE 0113-1:2007-06	Safety of machines - electrical equipment of machines - Part 1: General requirements (IEC 60204 - 1:2005, modified); German edition EN 60204-1:2006
DIN EN 60529, VDE 0470-1:2000-09	Protection classes using housings (IP code) (IEC 60529:1989 + A1:1999); German edition EN 60529:1991 A1:2000
DIN EN 60243-2, VDE 0303-22:2001-10	Electrical dielectric strength of insulating materials - testing procedures - part 2: Additional requirements for testing with direct current (IEC 60243-2:2001); German edition EN 60243-2:2001
DIN EN 60093, VDE 0303-30:1993-12	Testing procedures for electrical insulation: Specific dielectric strength and specific surface resistance of solid, electrically insulating materials (IEC 60093:1980); German edition HD 429 S1:1983
DIN EN 60167, VDE 0303-31:1993-12	Testing procedures for electrical insulation: Insulation resistance of solid, insulating materials (IEC 60167:1964); German edition HD 568 S1:1990
DIN EN 60112, VDE 0303-11:2003-11	Process for determining the test figures and comparison figures for creepage path formation in solid, insulating materials (IEC 60112:2003); German edition EN 60112:2003

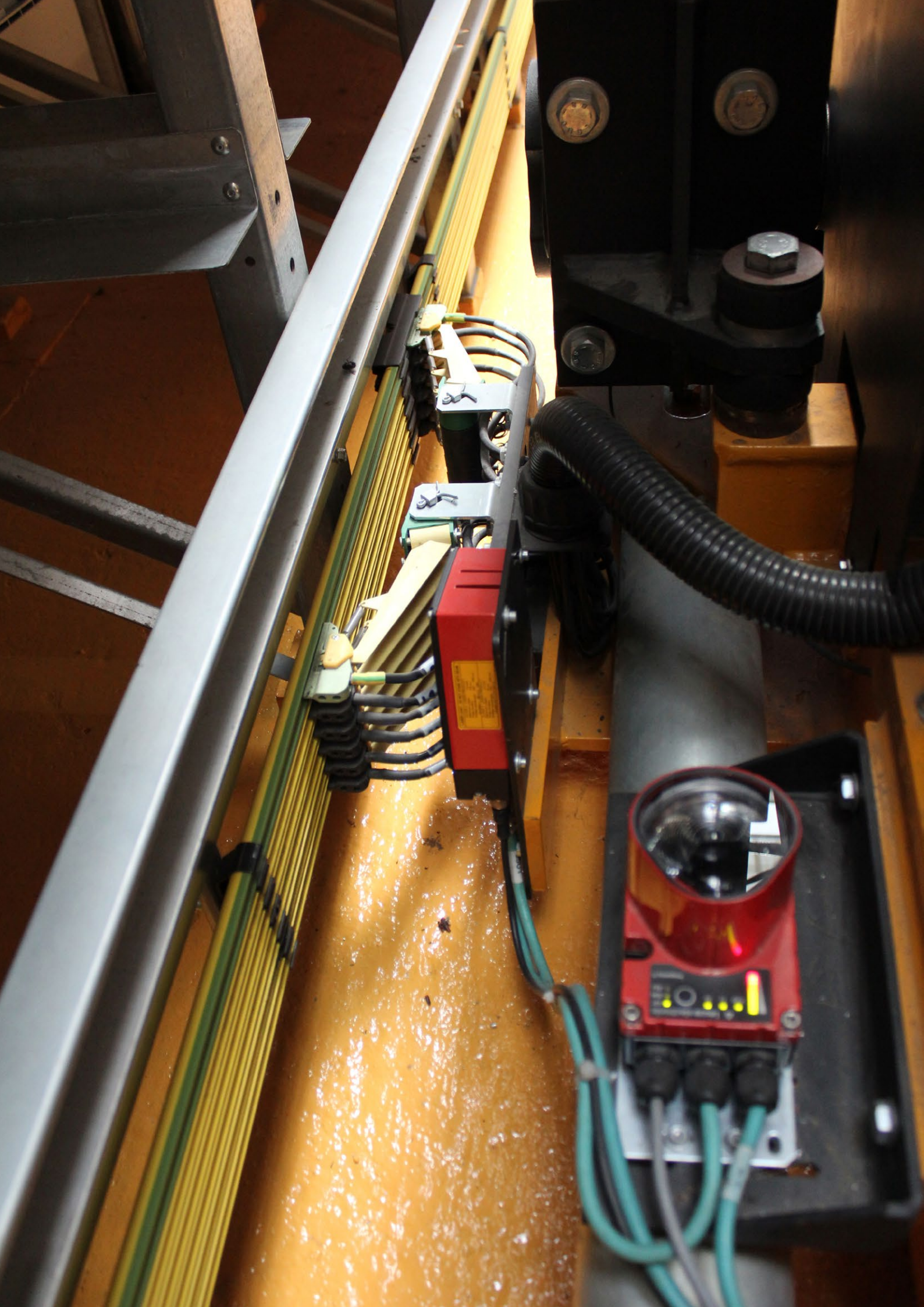

Project Planning

Technical Notes and Engineering Information

1. Application area and intended use

The Conductor Rail System 0811 is designed as a modular, single-pole, and insulated system. Intended applications are facilities with mostly curved tracks and circular or oval applications with or without switches. Typical applications are electrified monorail systems, conveyors, sorters, and other conveyor systems in circular and oval arrays, as well as other indoor and weatherproof outdoor applications.

Use in Electrified Monorail Systems (EMS):

Specific components and accessories are available for this scope of application (please see catalogue KAT0800-0002 "Conductor Rails for Electrified Monorail Systems"). For use in applications and/or requirements other than described, please contact us.

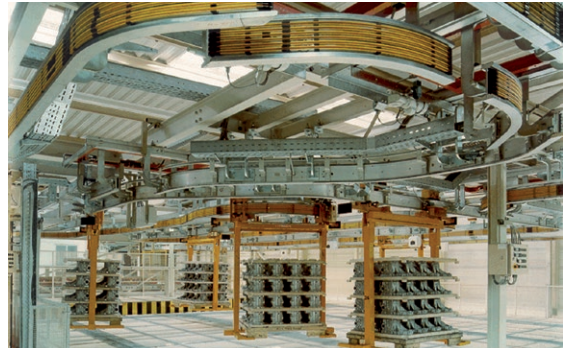

2. Rail material and voltage drop

Conductor rails can be provided in copper or stainless steel, and for simple, short routings, in galvanized steel. Unlike typical linear track routings, electrified monorail systems, circular, and oval tracks have multiple power feeds and mostly small consumers, therefore voltage drop is not a critical factor. End Caps and Rail Connectors can be used as power feeding points.

3. Rail Connectors and Expansion Joints

The 0811 Program uses a unique and proven system of bayonet couplings. By enlarging the notch in the Conductor Rail, every Rail Connector can be used as an Expansion Joint, thus eliminating the need for additional Expansion Joints.

4. Power Feed

Rails are connected to the power supply network via Power Feed Connectors on the bayonet couplings. Additionally, End Caps and Rail Connectors can be used as Power Feeds by adding Cable Lugs.

5. Air Gaps and Insulating Elements

These are used to separate sections or as ejection points for foreign bodies and abrasions. Air Gaps, unlike Insulating Elements, allow for safe electrical isolation even in case of material pollution and high abrasion. Insulating Elements for older facilities with block operation are available on request.



6. Anchor Clamps

Anchor Clamps are used to fasten the rails at specified distances and fixed points. Fixed points are reference points where the rails are fastened to the sub-structure by Anchor Clamps and Hanger Clamps. From the fixed point the rail can expand and slide into the adjacent Hanger Clamp. The fixed point keeps the rail in place and keeps the system from slipping.

7. End Caps and Transfer Points

End Caps are used to close rail end points and for protection against accidental contact with the rails. Transfer Points allow for the passage of graphite shoes between two disjoined rail sections. When used as Transfer Points, adjacent caps have to be aligned within a narrow tolerance range and factors like thermal expansion or varying load-carrying capacities causing mismatching rails must be taken into account. Crossing points, such as switches, lifters, etc. should be adjusted with hangers with medium to maximum load. If the rails cannot be adjusted due to the use of too few hangers, the system is not to be used until the crossing points have been properly aligned. Misalignment may result in damage to the Caps and Current Collectors. If setting a switch or lifter is possible, inspection intervals and setting values of the switch should be noted in the maintenance records to prevent rail system failures due to altered conditions at the crossing points.

Project Planning

Technical Notes and Engineering Information

8. Hanger Clamps

Sliding Hanger Clamps are used to fasten and position the rails. They ensure safe mounting of the rails while allowing the conductor rail to slip within the hanger in case thermal expansion occurs. Hanger Clamps are made from high-strength engineered plastic and are resistant to aging. Damage from aromates from the environment may occur if concentration and exposure time are exceeded. Hanger Clamps, as well as other plastic parts of the system, must not be painted or cleaned with solvents. Installation on painted surfaces is permissible only after drying and complete evaporation of the solvent. Please contact us if the system is to be used in facilities with aromate residue, such as flavor enhancers, benzenes, pickling agents, solvents and related substances. In this case, alternative plastics should be specified.

9. Pickup Guides

Pickup Guides are used at transfer points with greater distances or as entry points for additional vehicles. When using Pickup Guides within track routings, tolerances during the various operating states have to be considered. When using Pickup Guides, Current Collectors with spacers must be used to ensure correct distances (pole spacing) between decoupled Current Collector Shoes. The Pickup Guides are insulating components as well as plastic running surfaces and are subject to wear.

10. Current Collectors

When correctly installed Current Collectors provide proper contact with the Conductor Rails and are available with copper-graphite and pure carbon contact shoes. To ensure positive contact, installation distances and alignment with the rails' running tread must be maintained by the customer. Positional changes due to curves or mounting tolerances must be allowed for when the system is active. The stated tolerances for the Current Collector refer to new, not yet worn-out contact surfaces. Simultaneous exploiting of the maximum x and y tolerances is not permissible.

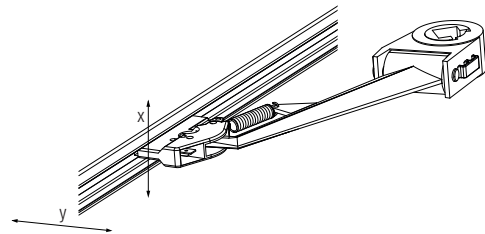

Special attention should be paid to the mounting position of the Current Collectors in rail circuits with curves. Ideally, Current Collectors should be mounted level with the rail contact point of the carriage. Deviating the Collector mounting positions as well as curves themselves change the distance to the rail and therefore modify the shoe pressure applied. This may result in increased wear of contact surfaces, possible damage to the system. Cables connected to the Current Collector must not exert pulling force on the Collector. Cables must be highly flexible so as to not deflect, move, change the shoe pressure on the rail, or limit the movement of the Current Collector.

If the Current Collectors are to be installed within maintenance hatches, as is common with electrified monorail systems, sufficient free space for the cables must be provided. Flap hinges and latches have to be installed free of play and preferably adjustable, to avoid mismatching and vibrations. Foreign bodies like fastening screws must not compromise the movement of the cables and Current Collectors. Foreign bodies must not protrude into the mounting space of the Current Collectors.

Copper-Graphite and Carbon Collector Heads

Copper-Graphite Collector Heads

Copper Graphite shoe material has a high mechanical strength and can be used to transmit higher currents. They are applied in systems containing Pickup Guides and multiple transfer points.

Pure Carbon Collector Heads

Carbon Shoes are made from specially processed graphite material and combine good sliding and contact properties. Due to the high lubricant content of these shoes, they exhibit great running smoothness and high durability with less abrasion. They are well suited for data transmission due to low transition resistance (recommended minimum current load: 1 A). Their use for higher current loads is restricted. Pure Carbon Heads are brittle when compared to Copper-Graphite Heads. Therefore, to avoid breaking the Pure Carbon Shoes, it is recommended that new systems be run with Copper-Graphite Heads first, then switching to Pure Carbon Heads after the system has been broken in or when Collector Head replacement is due.

Durability

Since durability depends primarily on ambient conditions such as humidity, system behavior, velocity, operating mode, installation position, etc., statements about durability can be made only in context. Guidance values are available on request.

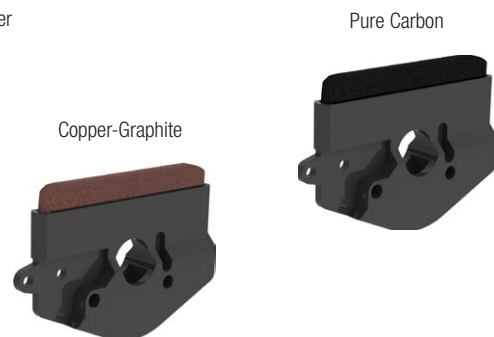

Project Planning

Conductor Rail System Dimensioning

The rail type is selected according to the total expected load current per route section and the voltage drop during start-up.

Notes on voltage drop and special operating conditions

The total current of all consumers running simultaneously must not exceed the stated load capacity of the rail at 100% duty cycle. Voltage drop on the conductor rail should not be higher than 3-5% U_N . If facilities operate under extreme environmental conditions, please contact us.

Calculating the voltage drop

Three-phase current	Alternating current	Direct current		
$\Delta u = \sqrt{3} \times L \times I_g \times Z \text{ [V]}$	$\Delta u = 2 \times L \times I_g \times Z \text{ [V]}$	$\Delta u = 2 \times L \times I_g \times R \text{ [V]}$	Δu = Voltage drop	[V]
			I_g = Total current	[A]
			R = resistance of the conductor rail	[Ω /m]
			Z = impedance of the conductor rail	[Ω /m]
			L = conductor rail length	[m]

Notes on rated current and dependence on ambient temperature

The conductor rails' specified rated current refers to a duty cycle of 100% according to European standards and to an ambient temperature of 35°C.

The conductor rail will not exceed the maximum tolerable rail temperature under these conditions. At lower temperatures and shorter duty cycles the rail can handle higher current loads. A current load increase up to the maximum tolerable rail temperature is permissible.

At temperatures higher than the reference value for the rated current at 35°C, self-heating needs to be reduced. In practice, this can be done by reducing the current load or shortening the duty cycle.

Permissible ambient temperature dependent on duty cycle (specified for copper rail 100 A)

Duty cycle	100%	80%	60%	40%	20%
Permissible ambient temperature with standard insulation	55°C	57.5°C	60°C	62.5°C	65°C
Permissible ambient temperature with heat-resistant insulation	85°C	92.5°C	100°C	107.5°C	110°C

Rail Layout and Curves

Constructing curves is preferably done on-site by means of a bending device (see page 29). A straight section of at least 65 mm on each end of the curve is necessary for connecting.

Rails can be bent down to the following radii:

Smallest possible radius	At the factory	On-site
Vertical	400 mm	500 mm
Horizontal	1200 mm	2000 mm

For further information on curves, please see page 15

Horizontal rail arrangements

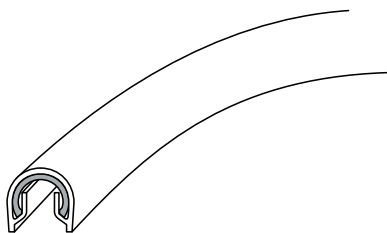

Vertical rail arrangements

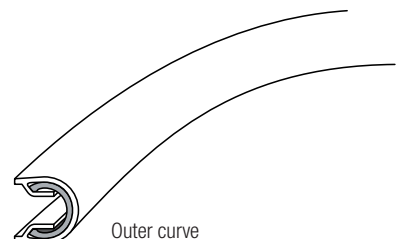
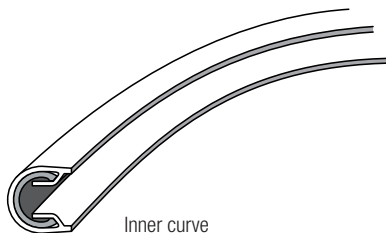

Project Planning

Using Rail Connectors as Expansion Joints

If the conductor rail is installed inside or alongside a support structure, such as a crane runway or building's structure, changes in temperature will cause changes in the lengths of the support profile as well as the conductor rail. Due to the different materials used, the degree of expansion will vary. These variations, as well as expansion through self-heating or exposure to external heat sources must be compensated for to prevent compressing or warping of the conductor rail.

Expansion Joints are generally used for this purpose. With the 0811 system, the 081121 and 081122 Rail Connectors act as expansion units, by cutting the notch according to Diagram 1 below.

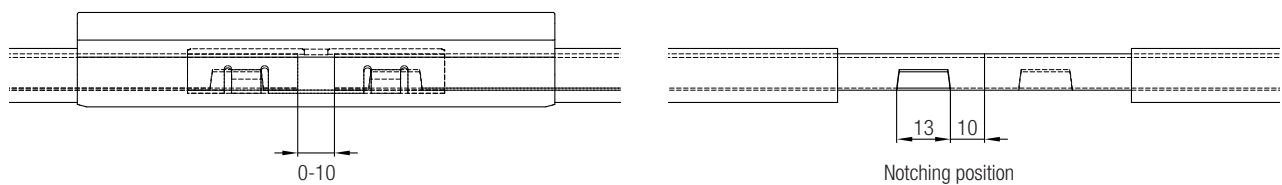

Diagram 1 – Adjusting the Air Gap

Example

Temperature range: from +10°C (t_{\min}) to +60°C (t_{\max})
(Ambient temperature during installation (t_{inst}): +25°C)

Definitions

t_{\min} = lowest temperature that occurs in the application
 t_{\max} = highest possible working temperature in the application

1. Draw a connecting line from t_{\min} to t_{\max}
2. Draw the ambient temperature during installation (t_{inst}) as a horizontal line
3. Draw a vertical line down from the point of intersection of these two lines and read off the air gap to be used during installation

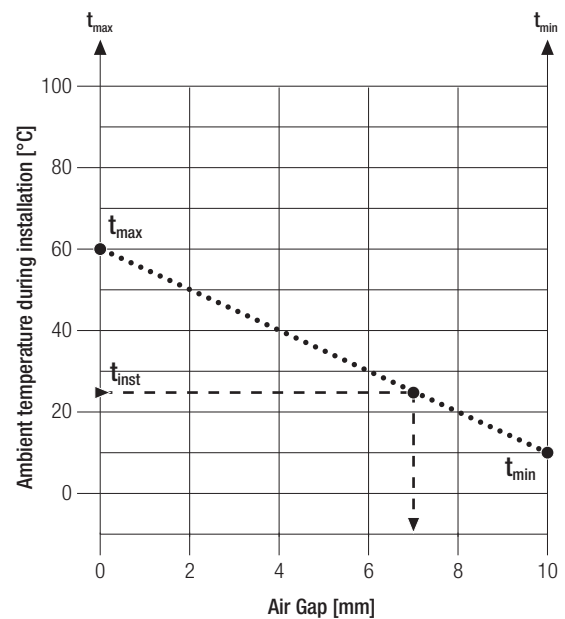

Example – expansion in buildings

Multiple Rail Connectors are installed at intervals to compensate for expansions occurring in buildings (e.g. 30 mm).

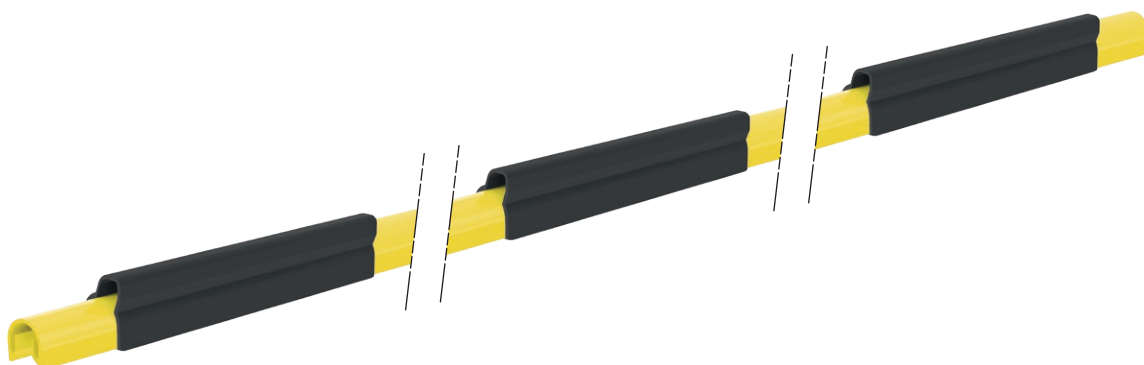

Project Planning

Diagram 2 – Number of Connector/Expansion Units when using Steel and Data Metal Rails > 100 m

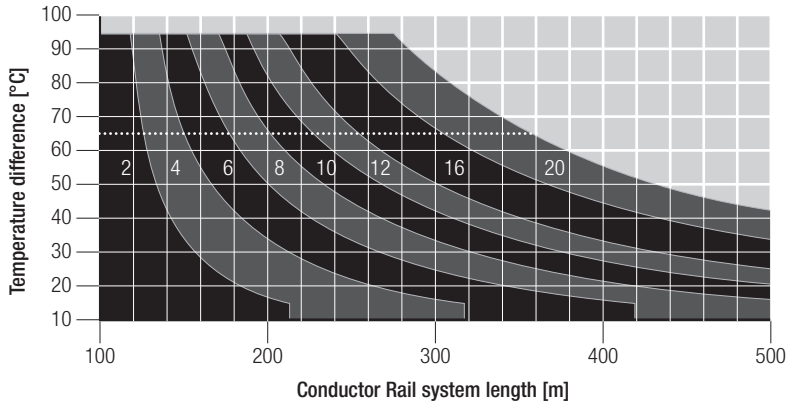

Temperature difference
= $\Delta rU + \Delta rsw$

ΔrU = Variability of ambient temperature

Δrsw = Temperature increase by electric current
= 5°C up to 50% duty cycle
= 30°C up to 100% duty cycle

Diagram 3 – Number of Connector/Expansion Units when using Copper Rails > 100 m

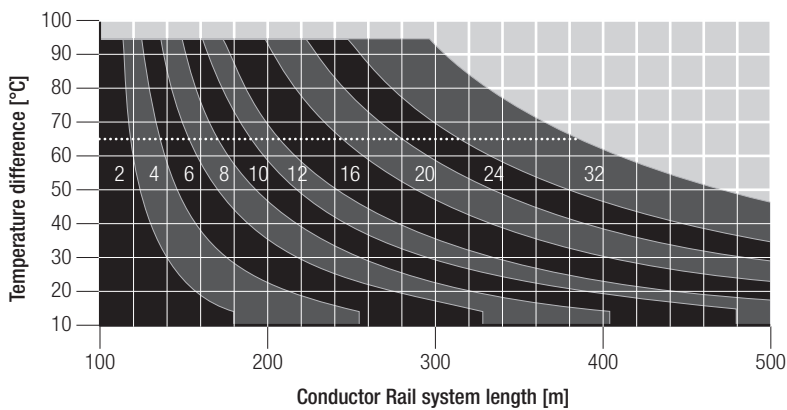
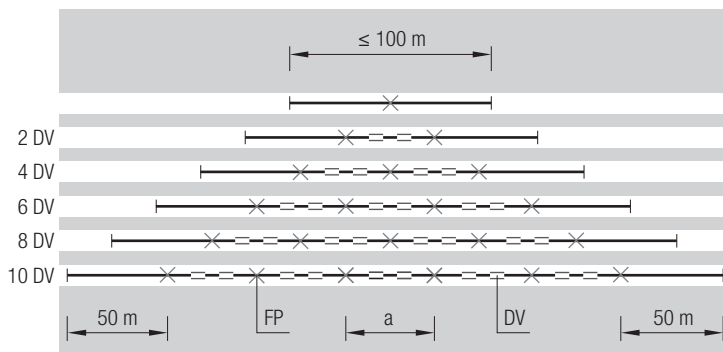

Diagram 4



DV = Connector/Expansion Unit
FP = Anchor Clamp
L = Total Length
a = Length inbetween two Expansion Units

$$a = \frac{(L - 100) \cdot 2}{\text{Number of DV}}$$

Two Expansion Units have to be installed in center between two Anchor Clamps!

Conductor Rail System Components

Insulated Conductor Rails

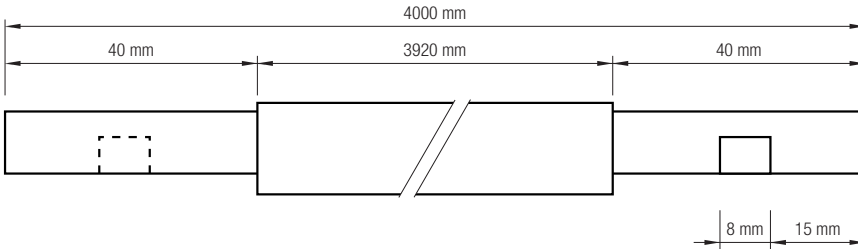

Scale 1:1

Rail Types

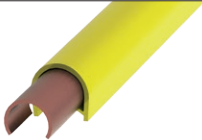
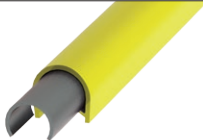
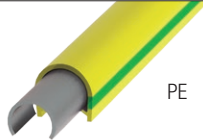
100A Solid Copper Rail	32A Galvanized Steel Rail	10A Data Metal Rail
		 PE
Type 081116	Type 081112	Type 081118

Insulation color: RAL 1018
(other colors by request)
Protective Earth (PE) insulation is marked with a green stripe on both sides.

Type / Conductor material	Rated current 100% duty cycle	Ambient temperature min. / max.	Insulation temperature max.	Part No.		Length [m]	Weight [kg]
				Phase PH	Protective earth PE		
Galvanized Steel	32 A	Standard (PVC) -10°C ... 55°C	Standard (PVC) 85°C	081112-4x11	081112-4x12	4	1.180
Copper	100 A			081116-4x11*	081116-4x12*		1.280
Data Metal	10 A			081118-4x11*	081118-4x12*		1.200
Galvanized Steel	32 A	Heat-resistant (PPO/PPE) -10°C ... 85°C	Heat-resistant (PPO/PPE) 115°C	081112-4x21	081112-4x22		1.180
Copper	100 A			081116-4x21	081116-4x22		1.280
Data Metal	10 A			081118-4x21	081118-4x22		1.200

Note: Please contact us if your temperature ranges differ from the above

* Standard range

Rail Connectors



One-piece cover for power feeds up to 6 mm²



Two-piece cover for power feeds up to 10 mm²

Type of rail connection	Use one-piece cover	Use two-piece cover
Straight rails 10 A - 100 A	x	x
Slip rings/curved tracks (r < 2 m)		x
Power feeds up to 6 mm ²	x	x
Power feeds up to 10 mm ²		x

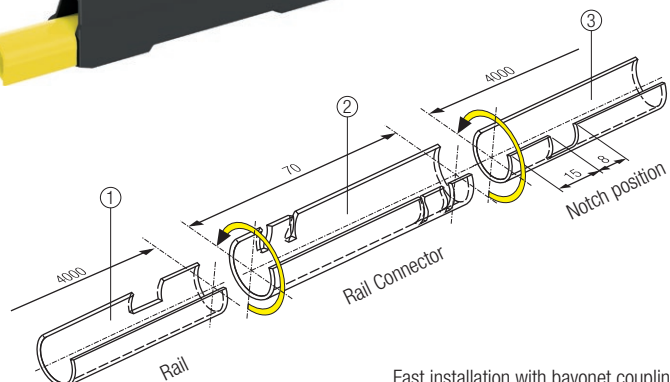

Fast installation with bayonet couplings

Rail Connector with insulating cover	Part No.		Weight [kg]
	For steel and data metal rails	For copper rails	
One-piece cover (see table above)	081121-2	081121-6	0.050
Two-piece cover (see table above)	081122-2*	081122-6*	0.050

* Standard range

Conductor Rail System Components

Curves

By using the Bending Device (see page 29), the rails can be adjusted to the needed routing or formed in a circular fashion on-site. Smaller curves or circular segments can be ordered from the factory as standard parts.

Hanger Clamp Alignment for Curves

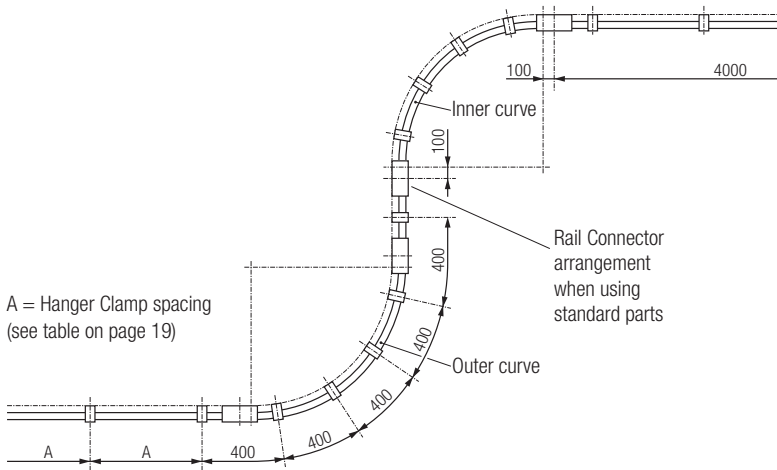

Vertical rail arrangements



Horizontal rail arrangements

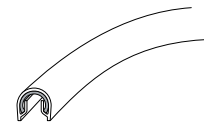

Standard 0811 Curves

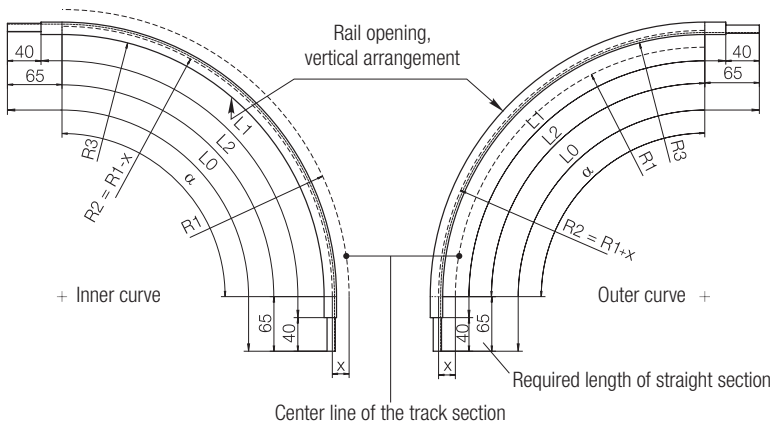

- L_0 = Rail section
- L_1 = Insulating section
- $L_0 = L_2 + 130$
- $L_1 = L_2 + 50$

$$L_2 = \frac{R_2 \cdot \pi \cdot \alpha}{180}$$

- R_1 = Radius of the track section
- R_2 = Radius of the contact surface
- R_3 = Inside radius of the conductor rail
- $X = 20 + \alpha$
- α = Distance between R_1 and the seat area of the Hanger Clamp:
 - Installed on track section = 15 mm
 - Installed on support arm or C-rail = 17 mm

Part Nos. for Curves

Galvanized Steel Rail	Min. Radius	Part No.
081112 HOR. 32A PH St-Is	>1500	081112 - HB x 11
081112 HOR. 32A PE St-Is	>1500	081112 - HB x 12
081112 HOR. 32A PH Wf-Is	>1500	081112 - HB x 21
081112 HOR. 32A PE Wf-Is	>1500	081112 - HB x 22
Copper Rail	Min. Radius	Part No.
081116 HOR. 100A PH St-Is	>960	081116 - HB x 11
081116 HOR. 100A PE St-Is	>960	081116 - HB x 12
081116 HOR. 100A PH Wf-Is	>1250	081116 - HB x 21
081116 HOR. 100A PE Wf-Is	>1250	081116 - HB x 22
Data Metal Rail	Min. Radius	Part No.
081118 HOR. 10A PH St-Is	>1500	081118 - HB x 11
081118 HOR. 10A PE St-Is	>1500	081118 - HB x 12
081118 HOR. 10A PH Wf-Is	>1500	081118 - HB x 21
081118 HOR. 10A PE Wf-Is	>1500	081118 - HB x 22

Galvanized Steel Rail	Min. Radius	Part No.
081112 VER. 32A PH St-Is	>900	081112 - VB x 11
081112 VER. 32A PE St-Is	>900	081112 - VB x 12
081112 VER. 32A PH Wf-Is	>900	081112 - VB x 21
081112 VER. 32A PE Wf-Is	>900	081112 - VB x 22
Copper Rail	Min. Radius	Part No.
081116 VER. 100A PH St-Is	>900	081116 - VB x 11
081116 VER. 100A PE St-Is	>900	081116 - VB x 12
081116 VER. 100A PH Wf-Is	>900	081116 - VB x 21
081116 VER. 100A PE Wf-Is	>900	081116 - VB x 22
Data Metal Rail	Min. Radius	Part No.
081118 VER. 10A PH St-Is	>900	081118 - VB x 11
081118 VER. 10A PE St-Is	>900	081118 - VB x 12
081118 VER. 10A PH Wf-Is	>900	081118 - VB x 21
081118 VER. 10A PE Wf-Is	>900	081118 - VB x 22

St-Is = Standard Insulation up to 35°C

Wf-Is = Heat-resistant Insulation up to 85°C

Conductor Rail System Components

Power Feed Connectors

Power feed with cable lug 35 A (not for PE/protective earth connector!)

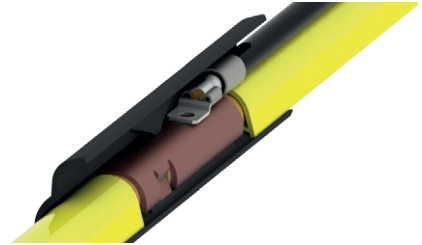
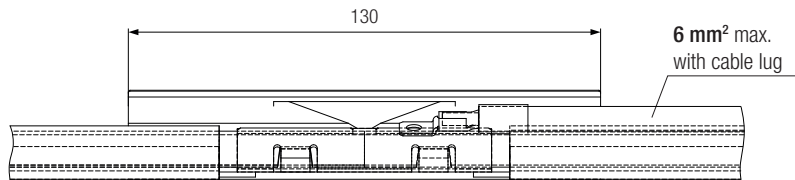

Power feed with insulating cover PH with cable lug 6.3 mm	Rated current 100% duty cycle	Part No.		Weight [kg]
		For steel and data metal rails	For copper rails	
One-piece cover (see table page 14)	35 A	081151-21	081151-61	0.050
Two-piece cover (see table page 14)		081156-21*	081156-61*	

* Standard range

Power feed with crimp cable lug 45 A and PE/protective earth connector

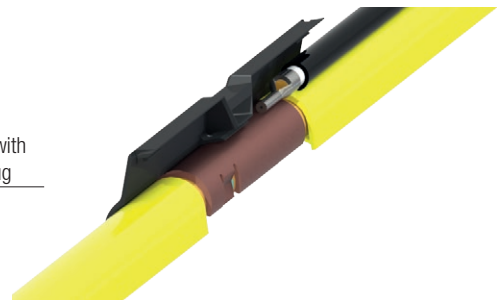
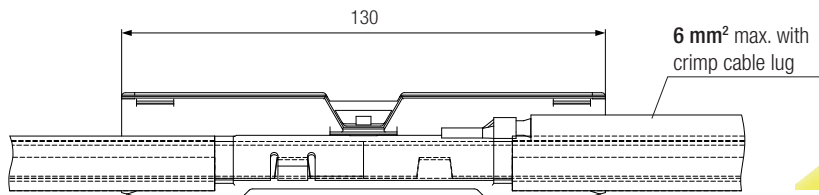

Power feed with insulating cover PH + PE with crimp cable lug	Rated current 100% duty cycle	Part No.		Weight [kg]
		For steel and data metal rails	For copper rails	
One-piece cover (see table page 14)	45 A	081151-22	081151-62	0.050
Two-piece cover (see table page 14)		081156-22*	081156-62*	

* Standard range

Power feed with crimp cable lug 100 A and PE/protective earth connector

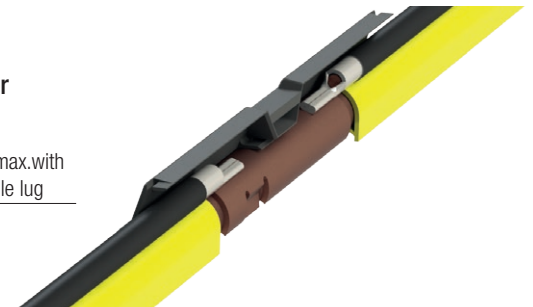
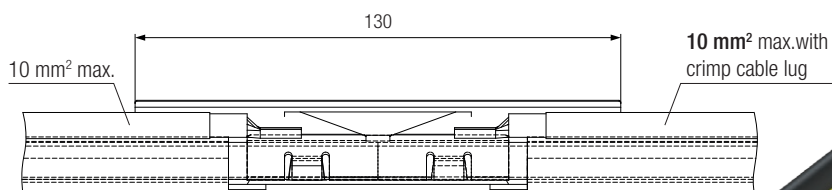

Power feed with insulating cover PH + PE with crimp cable lug	Rated current 100% duty cycle	Part No.		Weight [kg]
		For steel and data metal rails	For copper rails	
One-piece cover (see table page 14)	100 A	081155-22	081155-62	0.070
Two-piece cover (see table page 14)		081157-22*	081157-62*	

* Standard range

Note: For protective earth connector, use crimp cable lug only!

Conductor Rail System Components

Anchor Clamps

Anchor Clamp 0811

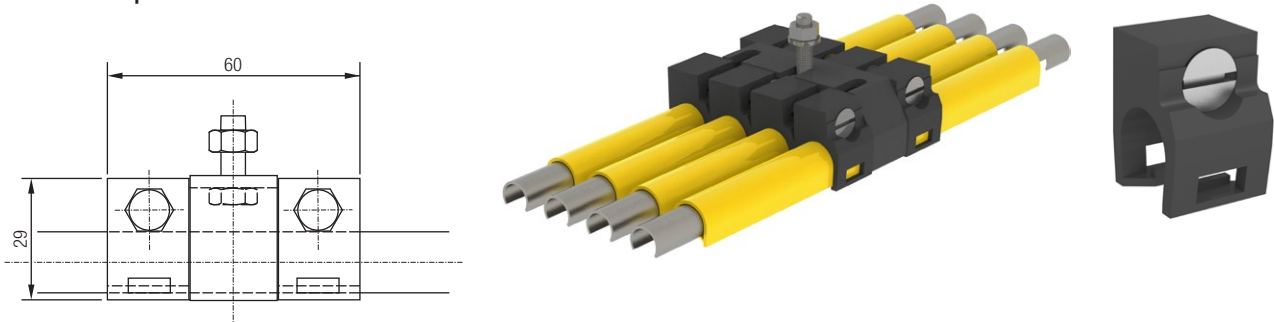

Type	Part No.	Weight [kg]
Anchor Clamp with ledge	081131*	0.014

* Standard range

Requirement: 2 Anchor Clamps per pole

Air Gap

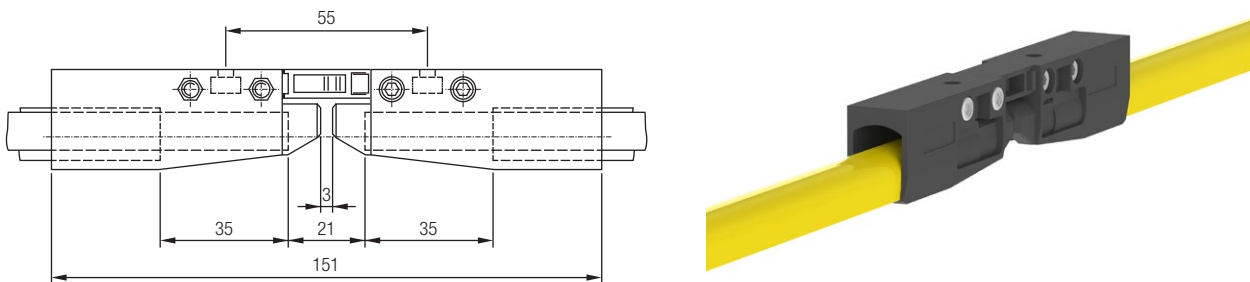

Type	Part No.	Weight [kg]
Air Gap	081195-21*	0.046

* Standard range

Note: Air Gaps can be used as power feeds by inserting a cable lug (see page 18)

Conductor Rail System Components

End Caps for Rail End Points and Transfer Points

End Caps can be used as power feeds by inserting a cable lug.

Note: If the end cap is used as a protective earth connector, use "crimp style" cable lug only!

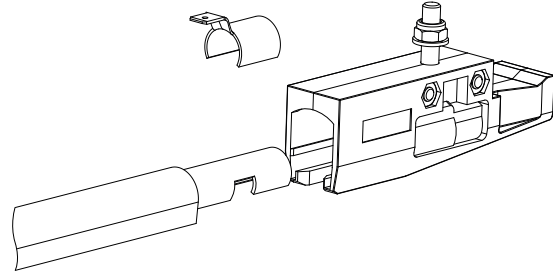

End Cap 081174

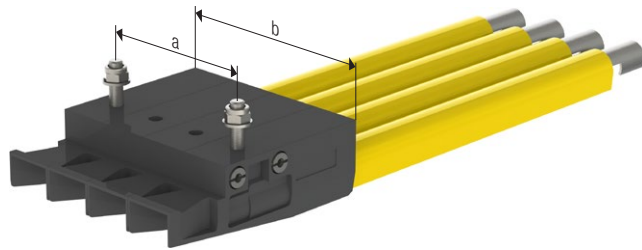
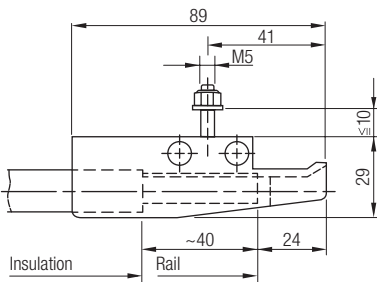

End Cap	Part No.		Dimension a [mm]	Dimension b [mm]	Weight [kg]
Type	Application	For galvanized steel and data metal rails			
1-pole without power feed	Phase and protective earth	081174-20x1x0*		–	0.025
3-pole without power feed		081174-20x3x0*		40	0.090
4-pole without power feed		081174-20x4x0*		60	0.115
5-pole without power feed		081174-20x5x0		40	0.140
6-pole without power feed		081174-20x6x0		60	0.165

* Standard range

Power Feed Cable Lugs

For End Caps used as power feeds these cable lugs are clipped on the rail.

Note: For End Cap Power Feeds used as protective earth, use connectors with crimp type cable lug only.

Power Feed Cable Lug 081154

For End Feed in End Caps (max. 6 mm², 35 A),
To be used for phase and control cables.

Type	Part No.	Weight [kg]
Power Feed Cable Lug for steel and data metal rails	081154-21*	0.005
Power Feed Cable Lug for copper rails	081154-61*	0.005

* Standard range

for End Feed in End Caps (max. 6 mm², 45 A),
to be used for phase, control, and protective earth cables.

Type	Part No.	Weight [kg]
Power Feed Cable Lug for steel and data metal rails	081154-22*	0.005
Power Feed Cable Lug for copper rails	081154-62*	0.005

* Standard range

Note: The Cable Lug must be clipped on the rail!

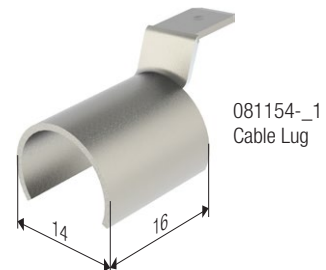

081154-1
Cable Lug

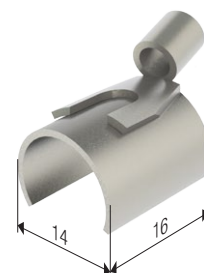

081154-2
Crimp Type Cable Lug

Conductor Rail System Components

Hanger Clamps

Hanger Clamps are compact, multi-poled clamps allowing for fast clip-on installation, securely fastening the conductor rails.

The installation permits smooth longitudinal sliding of the rails during thermal expansion of the system. Hanger Clamps are fastened to the substructure (Conductix-Wampfler C-Rails (Program 0230) or Support Arms) with threaded screws or square nuts.

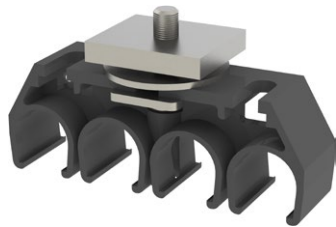

Rail material	Max. support distance "A" [m]		
	Suspended Rail	Crane Runway	Curves
Steel	0.8	1.0	0.4
Copper	0.5	0.8	
Data Metal	0.8	1.0	

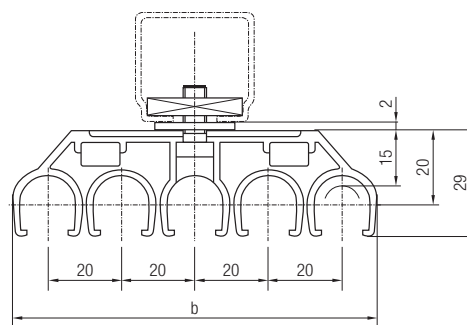
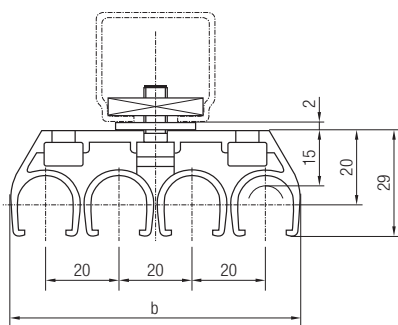
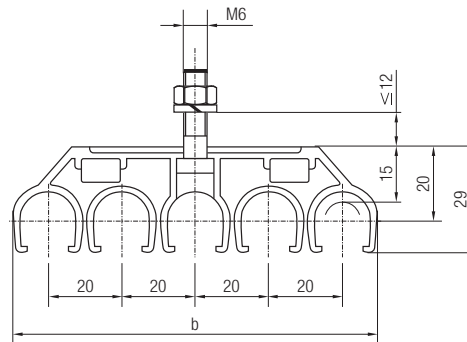
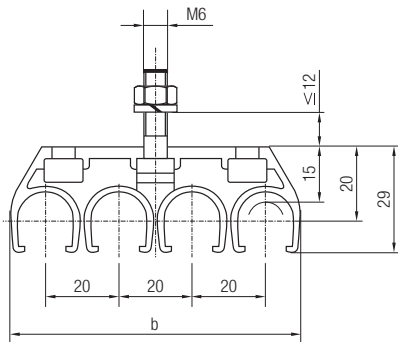
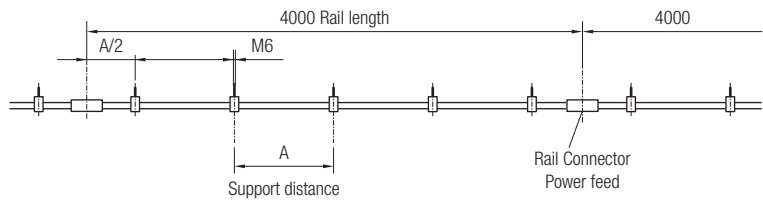

Hanger Clamp Type	Clear width "b"	Part No.		Weight [kg]
		With hex-nut	With square-nut	
3-pole	60 mm	081143-1x3x20*	081145-1x3x20*	0.030 / 0.060
4-pole	80 mm	081143-1x4x20*	081145-1x4x20*	0.035 / 0.065
5-pole	100 mm	081143-1x5x20*	081145-1x5x20*	0.040 / 0.070
6-pole	120 mm	081143-1x6x20*	081145-1x6x20*	0.045 / 0.075

* Standard range

Conductor Rail System Components

Installation example Hanger Clamps – Surface-mount with angle bracket

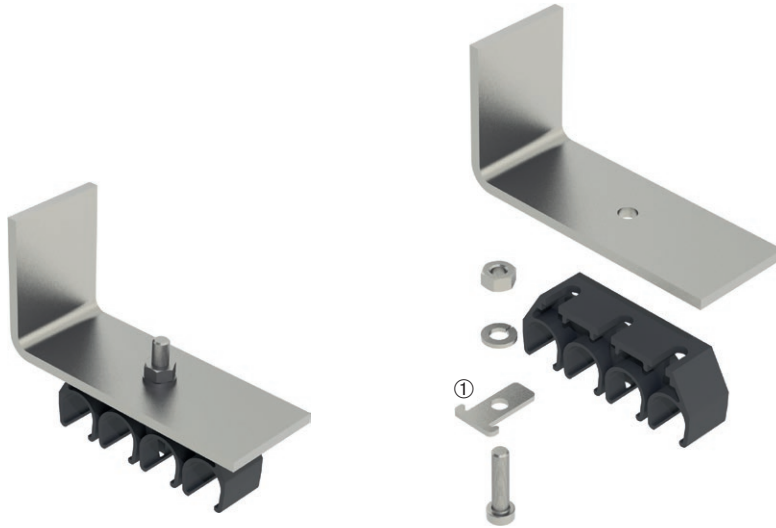

Installation example Hanger Clamps – Mounted on C-Rail (Program 0230) or Support Arm

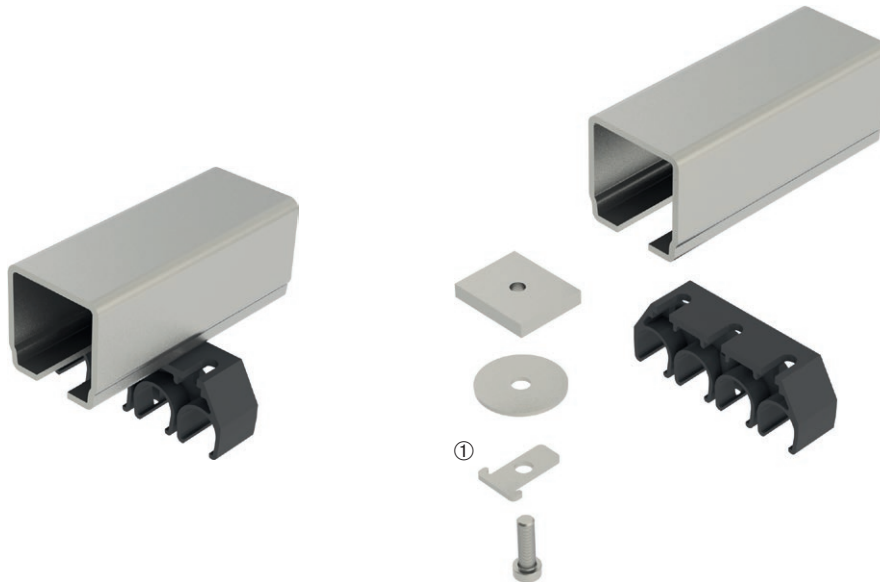

① Insert for force distribution. Hanger Clamps can be damaged if inserts are not installed.

Conductor Rail System Components

Pickup Guide 081182 – short type

To be used with short type Current Collectors 081101 and long type Current Collectors 081102 for transfer operations.

To compensate for misalignment of horizontal deflections ± 15 mm and vertical deflections of ± 8 mm.

Max. permissible transfer speed: 60 m/min. Higher speeds available by request.

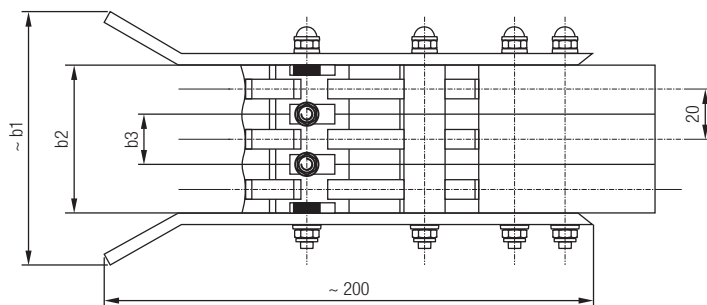
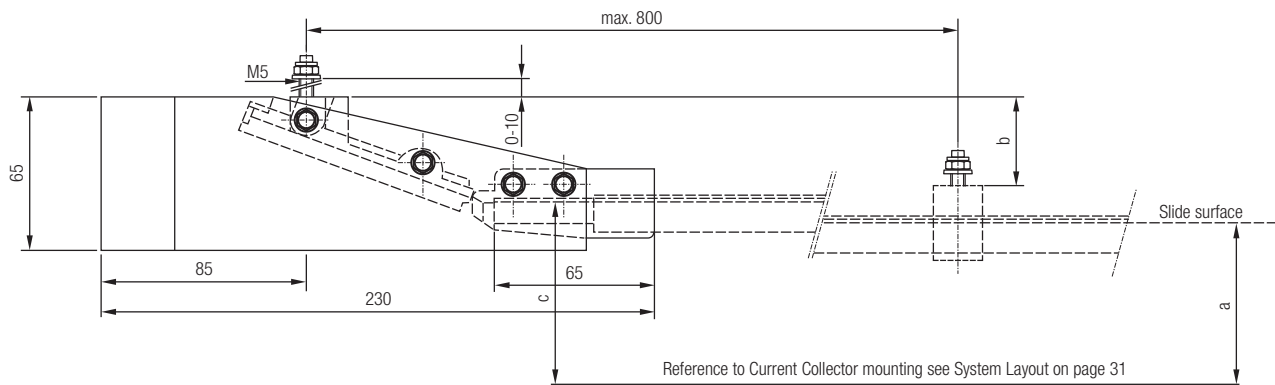
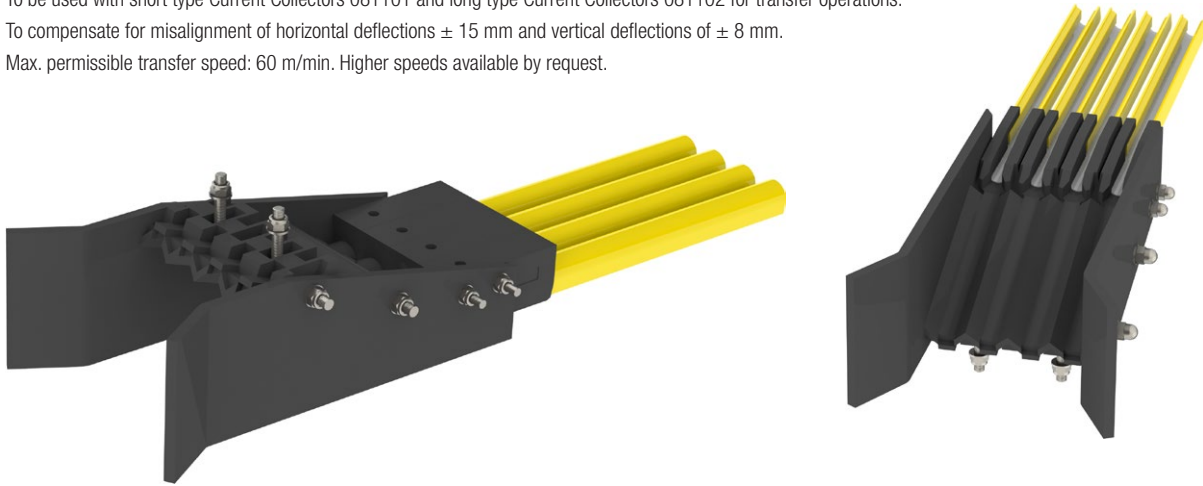

Type	a [mm]	b [mm]	c [mm]
Current Collector, short	50	38	60
Current Collector, long	75	43	90

The indicated nominal distance “a” between the center line of the Current Collector and the center line of the conductor rail must be changed by dimension “b” at the suspension of the pickup guide so that the clearance dimension “c” is guaranteed at this point.

A sufficient number of Current Collectors must be installed in systems utilizing pickup guides. The Current Collectors must be installed with the correct distances to ensure the right number of collectors for the current required.

The user has to ensure that while the collectors are between Pickup Guides they are de-energized or protected against accidental contact.

Type	Part No.	Number of poles	b1 [mm]	b2 [mm]	b3 [mm]	Weight [kg]
Pickup Guide 2-pole	081182-20x2x08	2	80	40	–	0.190
Pickup Guide 3-pole	081182-20x3x08	3	100	60	20	0.280
Pickup Guide 4-pole	081182-20x4x08	4	120	80	40	0.370

Higher pole numbers are available by request

Conductor Rail System Components

Pickup Guide 081182 – long type

To be used with long type Current Collectors 081102 for transfer operations.

To compensate for misalignment of horizontal deflections ± 30 mm and vertical deflections of ± 25 mm.

Max. permissible transfer speed: 80 m/min. Higher speeds available by request.

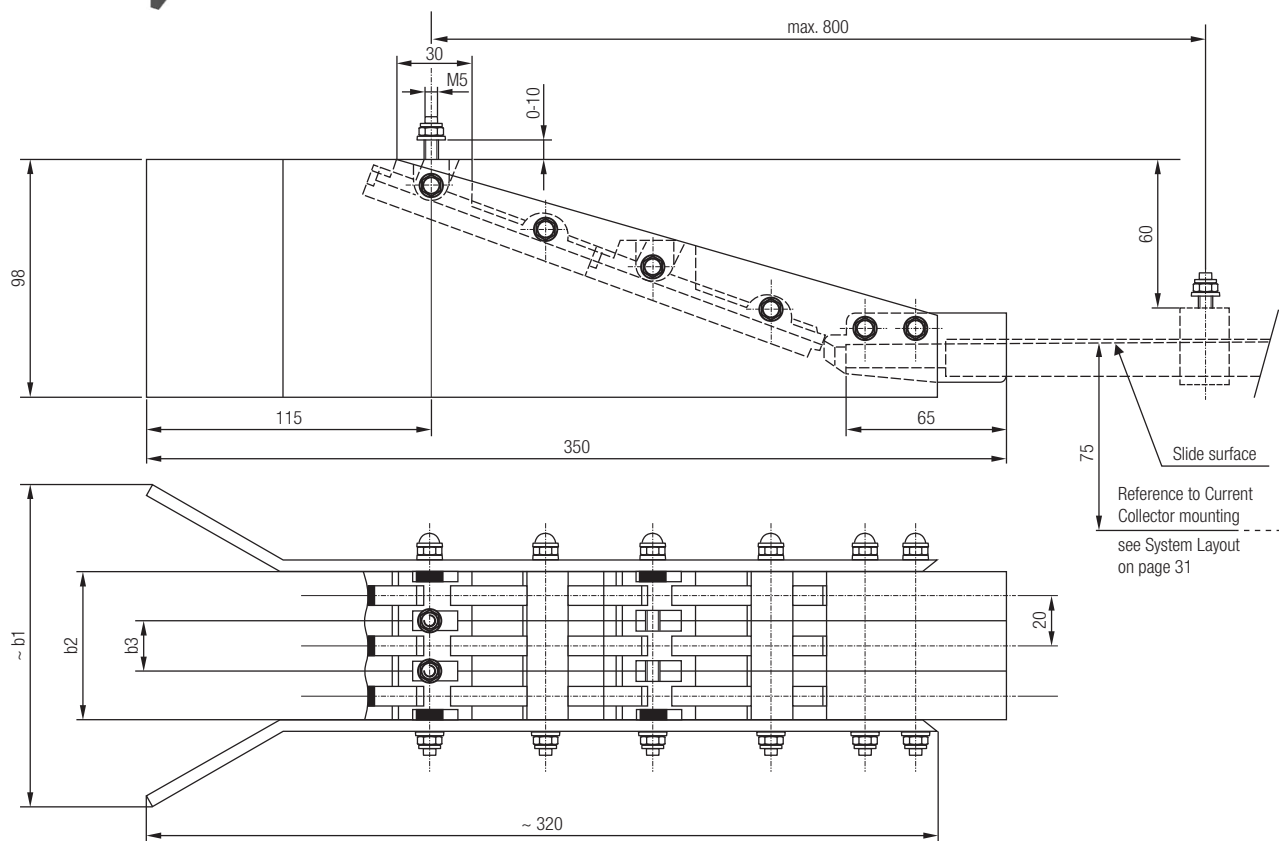
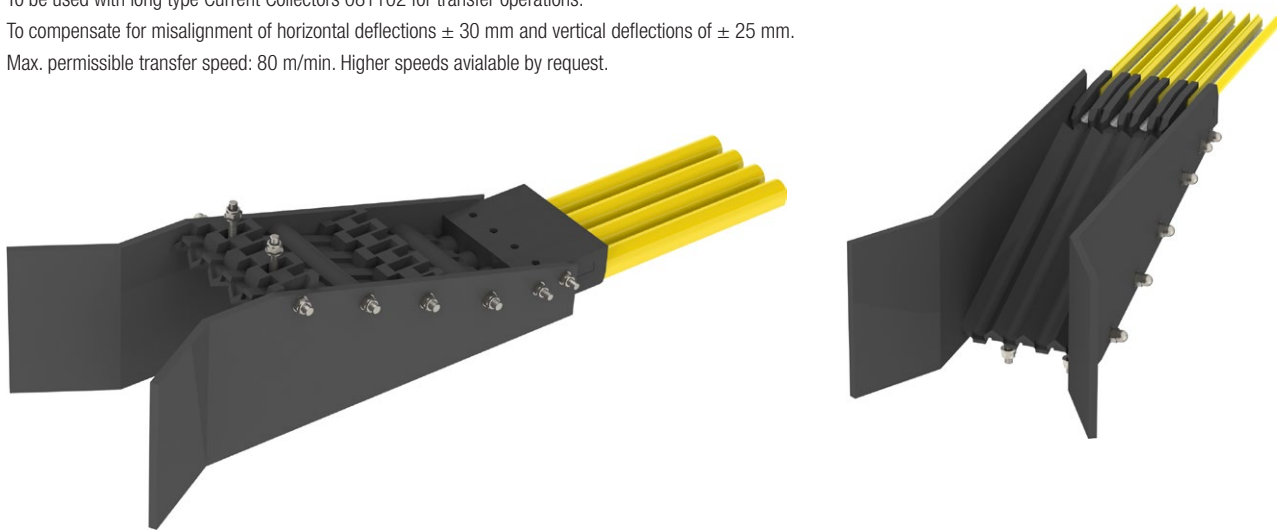

A sufficient number of Current Collectors must be installed in systems utilizing pickup guides. The Current Collectors must be installed with the correct distances to ensure the right number of collectors for the current required.

The user has to ensure that while the collectors are between Pickup Guides they are de-energized or protected against accidental contact.

Type	Part No.	Number of poles	b1 [mm]	b2 [mm]	b3 [mm]	Weight [kg]
Pickup Guide 2-pole	081182-20x2x25	2	110	40	–	0.540
Pickup Guide 3-pole	081182-20x3x25	3	130	60	20	0.600
Pickup Guide 4-pole	081182-20x4x25	4	150	80	40	0.660

Higher pole numbers are available by request

Current Collectors

Current Collectors in general

Depending on application and function, different types of Current Collectors are used:

Cranes and conveyor systems, circular and oval rail systems		Electrified monorail systems		Temporary structures and amusement park rides
		Automotive sector	Other monorail systems	
Current Collector short arm type 081101	Current Collector long arm type 081102	Current Collectors with safety system PE^{plus}	Current Collectors with safety system PE^{plus} as required in the automotive sector	Special versions are available by request with additional safety features and different set-up for higher dynamic requirements
Version 1 – short 40 mm-head: Preferred for systems with transfer points and separations with little variation in track course	Version 1 – short 40 mm-head: for systems with and without transfer points and separations with ordinary variations in track course	Please see catalogue KAT0800-0002 “Conductor Rails for Electrified Monorail Systems” for further information	Please see catalogue KAT0800-0002 “Conductor Rails for Electrified Monorail Systems” for further information	
Version 2 – long 63 mm-head: Preferred for systems with transfer points and separations with little variation in track course	Version 2 – long 63 mm-head: Current Collectors with spacers must be used for systems with transfer points			
Current Collectors with spacers must be used for systems with transfer points				

PH-Version = to be used as phase and control cable (marked in black)

PE = to be used as protective earth (marked in green)

Carbon material

Copper-Graphite Heads are used for higher current loads and systems with Pickup Guides. Pure Carbon Heads are preferred for lower current loads and data signals with higher running quality and low transition resistance between collector and conductor rail – not suitable for systems with Pickup Guides/transfer points and discontinued tracks (risk of breakage in case of collision).

Mounting position/tolerance notes

Current Collectors can compensate for deviations of the nominal line in X- and Y-direction within a tolerance range (see page 10). When choosing the mounting position in systems with inner and outer curves, the envelope curve and resulting deviations from the nominal line have to be taken into account. Vertical tolerances (contact of the Collector Head with the rail) refer to new, not yet worn-out Collector Heads (gross tolerance). Simultaneously exploiting the maximum x-y tolerances is not permissible.

When installing the Current Collectors in structures provided by the customer, fastening elements need to be installed free of play and vibrations, and placed in the required position (aligned with nominal distance to the conductor rail). If the Current Collectors are to be installed within maintenance hatches (as is common with electrified monorail systems), there must be sufficient free space to accommodate the cables. Flap hinges and latches have to be installed free of play and preferably adjustable to avoid mismatching and vibrations. Foreign bodies like fastening screws must not compromise the movement of the cables and Current Collectors. Foreign bodies must not protrude into the mounting space of the Current Collectors.

Reverse operation/towing operation

Current Collectors are available for reverse and towing operation. The Stabilization Springs' position reduces the carbon heads' tendency to wear unevenly in towing operation. This equalization is not necessary in reverse operation since the alternating directional movements (e.g. transfer cars or cranes) wear the carbon heads symmetrically.

Regardless of the Stabilization Springs' position both Current Collector configurations can be used in towing and reverse operation.

Carbon heads for towing operation are used when the movement profile exceeds 70% movement in towing direction.

For installation position of the Stabilization Spring, see page 28.

Current Collectors

Single Current Collectors and Mounting Accessories

Depending on application, different types of Current Collectors are used.

Arm length:

Short arm version is used for limited installation situations and little rail deviation from the ideal line. Long arm version is used for applications with bigger deviations (max. 30 mm) from the ideal line.

Length of Carbon Brush:

40 mm or 63 mm depending on system geometry and current load.

Carbon Brush material:

Use copper-graphite heads for higher current loads and applications with higher mechanical requirements. Use pure carbon heads for lower current loads and data signals.

Spacers:

When using Pickup Guides, Current Collectors with spacers must be used to ensure correct distances (pole spacing) between decoupled Current Collector Shoes.

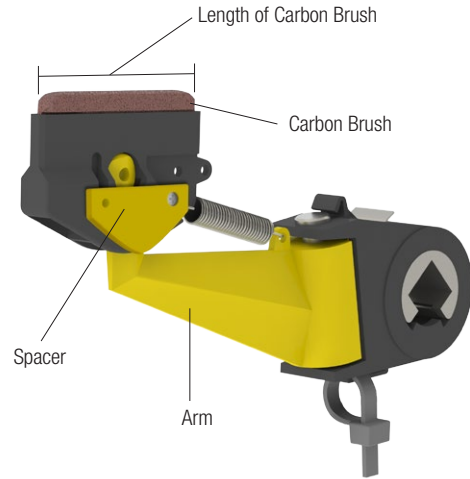

Short type Current Collector 081101 with 40 mm brush length for 16 A and 40 A

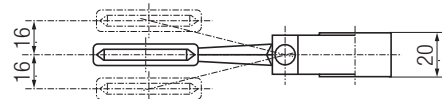
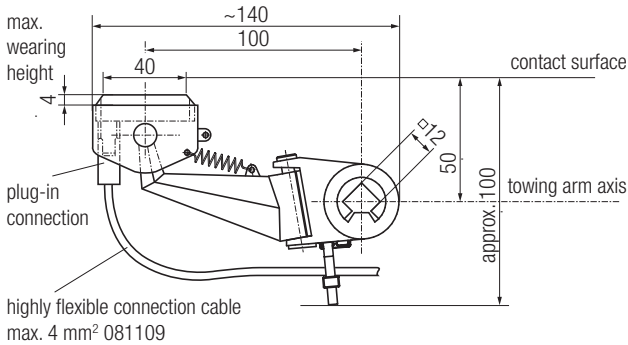

Type	Brush material	Part No.		Weight [kg]
		PH	PE	
Current Collector short type 1 x 16 A	Pure carbon	081101-0031*	081101-0032*	0.09
Current Collector short type 1 x 16 A with spacers for transfer points	Pure carbon	081101-3031	081101-3032	
Current Collector short type 1 x 40 A	Copper-graphite	081101-0011*	081101-0012*	
Current Collector short type 1 x 40 A with spacers for transfer points	Copper-graphite	081101-3011	081101-3012	

Note: connection cables must be ordered separately. Only highly flexible and double insulated cables must be used. Using the wrong cable increases abrasion of the carbon brushes and can cause strand fractures resulting in overload and subsequent damages. Caution: fire hazard!

* Standard range

Current Collectors

Short type Current Collector 081101 with 63 mm brush length for 16 A and 55 A

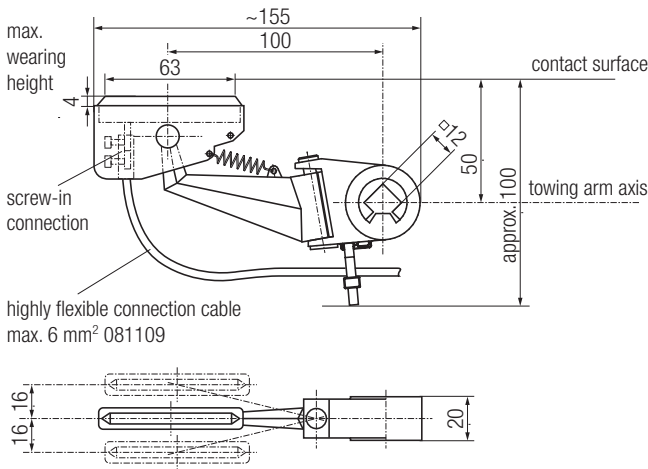

Clamping force: 7,5 N
Swivelling vertical ± 20 mm
Swivelling horizontal ± 16 mm

Type	Brush material	Part No.		Weight [kg]
		PH	PE	
Current Collector short type 1 x 16 A	Pure carbon	081101-0041*	081101-0042*	0.1
Current Collector short type 1 x 16 A with spacers for transfer points	Pure carbon	081101-3041	081101-3042	
Current Collector short type 1 x 55 A	Copper-graphite	081101-0021*	081101-0022*	
Current Collector short type 1 x 55 A with spacers for transfer points	Copper-graphite	081101-3021	081101-3022	

Note: connection cables must be ordered separately. Only highly flexible and double insulated cables must be used. Using the wrong cable increases abrasion of the carbon brushes and can cause strand fractures resulting in overload and subsequent damages. Caution: fire hazard!

* Standard range

Long type Current Collector 081102 with 63 mm brush length for 16 A and 55 A

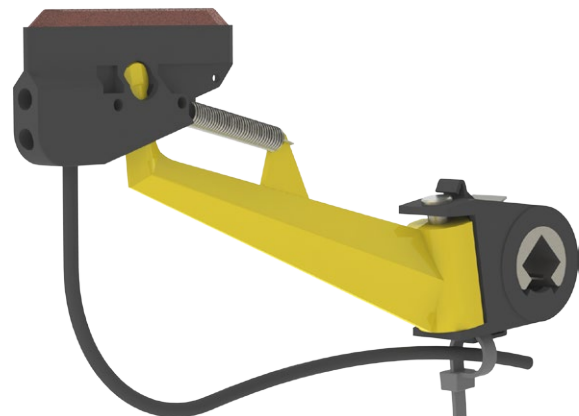
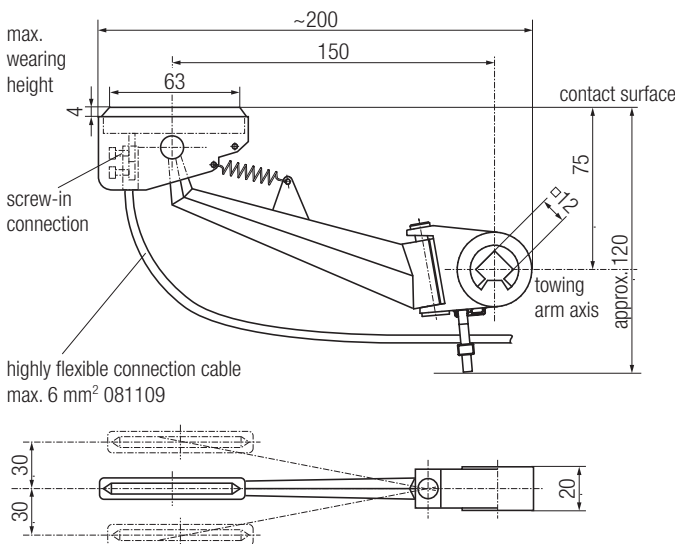

Clamping force: 5 N
Swivelling vertical ± 30 mm
Swivelling horizontal ± 30 mm

Type	Brush material	Part No.		Weight [kg]
		PH	PE	
Current Collector long type 1 x 16 A	Pure carbon	081102-0041*	081102-0042*	0.15
Current Collector long type 1 x 16 A with spacers for transfer points	Pure carbon	081102-3041	081102-3042	
Current Collector long type 1 x 55 A	Copper-graphite	081102-0021*	081102-0022*	
Current Collector long type 1 x 55 A with spacers for transfer points	Copper-graphite	081102-3021	081102-3022	

Note: connection cables must be ordered separately. Only highly flexible and double insulated cables must be used. Using the wrong cable increases abrasion of the carbon brushes and can cause strand fractures resulting in overload and subsequent damages. Caution: fire hazard!

* Standard range

Current Collectors

Towing Arm for Current Collectors

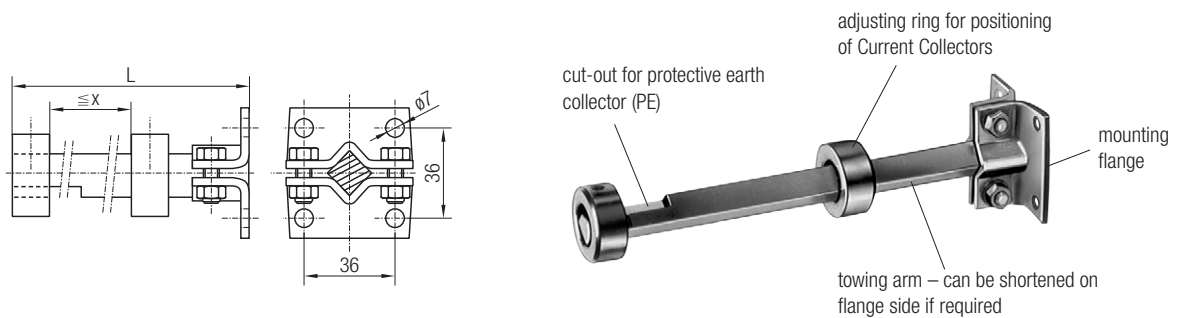

Type	Part No.	L [mm]	x [mm]	max. number of poles	Weight [kg]
Towing Arm	020194-200	200	140	7	0.440

Support Bracket for Current Collectors

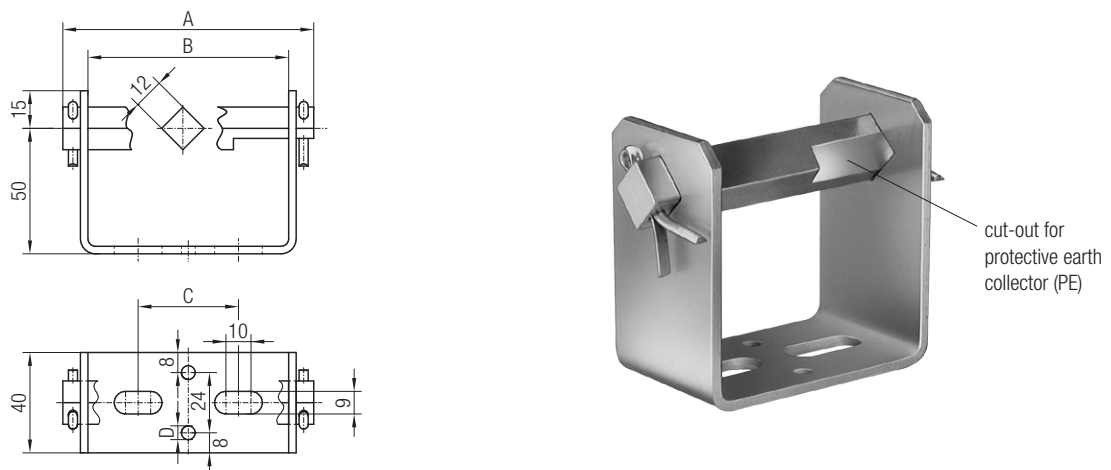

Type	Part No.	number of poles	A [mm]	B [mm]	C [mm]	D [mm]	Weight [kg]
Support Bracket	081050-20x2*	2	60	40	0	0	0.230
Support Bracket	081050-20x3*	3	80	60	30	5.5	0.300
Support Bracket	081050-20x4*	4	100	80	40	5.5	0.370
Support Bracket	081050-20x5*	5	120	100	50	5.5	0.440
Support Bracket	081050-20x6*	6	140	120	70	5.5	0.510
Support Bracket	081050-20x7	7	160	140	90	5.5	0.580
Support Bracket	081050-20x8	8	180	160	110	5.5	0.650
Support Bracket	081050-20x9	9	200	180	130	5.5	0.720
Support Bracket	081050-20x10	10	220	200	150	5.5	0.790

Note: protective earth collector can only be positioned on the outer side.

* Standard range

Connection Cables for Current Collectors

Connection Cables for Current Collectors 081101 and 081102

Connection Cable pre-assembled with AMP® connection for Current Collectors with short carbon brush (40 mm). Standard length is 1 m (other lengths available by request)

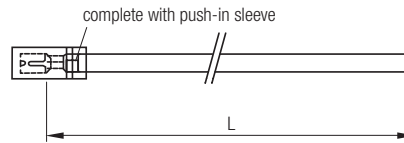

Cross-section [mm²]	Part No.		Length [m]	Cable diameter [mm]	Rated current [A]	Weight [kg]
	PH	PE				
1.5	081109-1x1,5x21	081109-1x1,5x42	1	4	25	0.014
2.5	081109-1x2,5x21	081109-1x2,5x42	1	5	34	0.023
4.0	081109-1x4x21	081109-1x4x42	1	6	45	0.037

Current designated for free installation in air

(SAP KONFIG 3126191)

Connection Cable (double insulated/highly flexible) pre-assembled with cable end sleeve for Current Collectors with long carbon brush (63 mm). Standard length is 1 m (other lengths available by request)

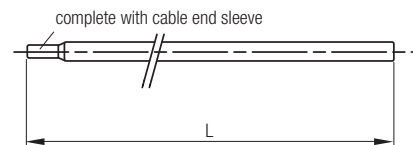

Cross-section [mm²]	Part No.		Length [m]	Cable diameter [mm]	Rated current [A]	Weight [kg]
	PH	PE				
1.5	081109-1x1,5x11	081109-1x1,5x32	1	4	25	0.014
2.5	081109-1x2,5x11	081109-1x2,5x32	1	5	34	0.023
4.0	081109-1x4x11	081109-1x4x32	1	6	45	0.037
6.0	081109-1x6x11	081109-1x6x32	1	7	57	0.056

Current designated for free installation in air

(SAP KONFIG 3126191)

Replacement Parts

Current Collector Head 48 mm with plug-in connection

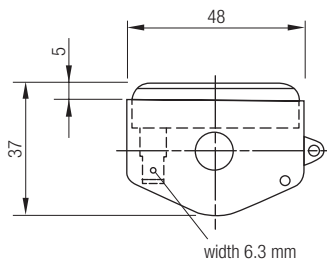

Part No.		Rated current [A]	Model	Material	Weight [kg]
081002-1x1	Head	16	PH	Pure carbon	0.010
081002-2x1	Head	16	PE	Pure carbon	0.010
081002-1x2	Head	40	PH	Copper-graphite	0.025
081002-2x2	Head	40	PE	Copper-graphite	0.025
08-D002-0566	Two spacers (for installation on the Collector Head – see page 24)				0.005

Current Collector Head 68 mm with screw-in connection

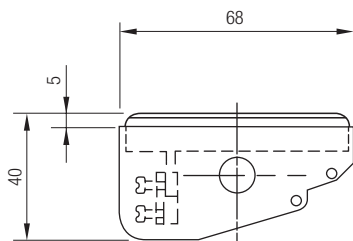

Part No.		Rated current [A]	Model	Material	Weight [kg]
081002-1x3	Head	16	PH	Pure carbon	0.020
081002-2x3	Head	16	PE	Pure carbon	0.020
081002-1x4	Head	55	PH	Copper-graphite	0.035
081002-2x4	Head	55	PE	Copper-graphite	0.035
08-D002-0566	Two spacers (for installation on the Collector Head – see page 24)				0.005

Note: Arms and Connection Cables on the Current Collectors are subject to wear and, like the Current Collector Head itself, have to be checked in regular intervals and replaced.

Current Collector Heads are replaced as follows:

- De-energize the system and secure it against re-engagement. Verify system is de-energized
- Pull out the Current Collector(s) from the rail
- Unhinge the Stabilizing Spring on the Current Collector Head (do not over-extend spring)
- Loosen the connection cable
- Rotate the Current Collector Head laterally as far as it will go and pull it off beyond the snap point
- Install new Current Collector Head in reverse order

Stabilizing Spring for Current Collector Heads

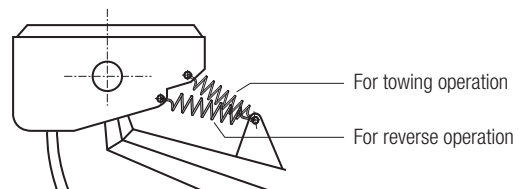
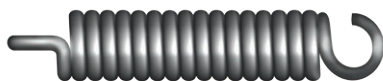

Part No.	Type	for Current Collector Heads	Brush length [mm]
08-RZ-056I	Replacement Spring	081101 / 081102	40 / 63
08-RZ-024AEI	Replacement Spring	081106	40
08-RZ-040I	Replacement Spring	081106	63

Tools

Bending Device 081081

This triple-roll Bending Device curves conductor rails with insulation covers in all four planes. By setting the adjusting screw any curve with a bending radius of 500 mm up to ∞ in the vertical plane and 1500 mm up to ∞ in the horizontal plane can be bent on-site. Please ask us if smaller bending radii are needed. To avoid deformation, plastic inserts must be used when bending laterally and must be removed after bending.

Type	Part No.	Weight [kg]
Bending Device	081081*	15.8
Plastic Insert (2 pcs.)	08-V015-0084	0.20

* Standard range

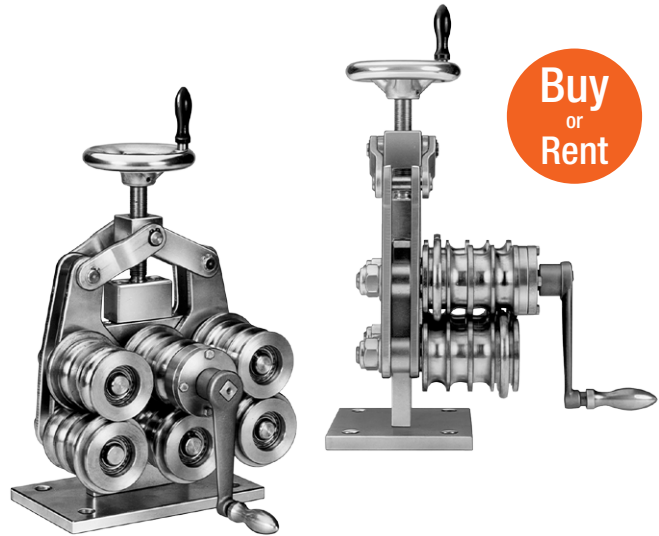

Notching Pliers 081082

If conductor rails are cut to length for isolating joints or to fit pieces etc., notches must be remade. The notches can be made in the factory or on-site by adjusting the set wheel to the respective position:

Position "V": notches for rail connectors

Position "B": notches for isolating joints

Position "D": notches for expansion joints

Type	Part No.	Weight [kg]
Notching Pliers	081082*	1.460
Replacement Cutting Punch	08-W100-0494*	0.10
Replacement Die Plate	08-W100-0495	0.10

* Standard range

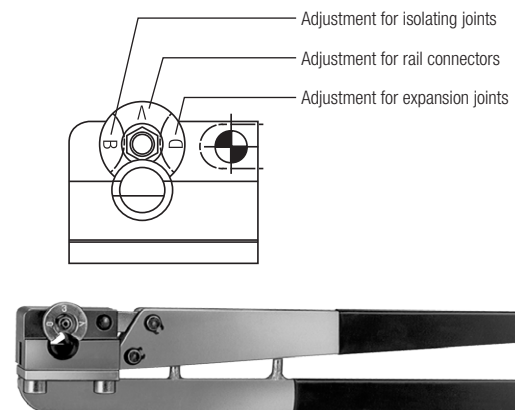

Cutting Pliers 081086

With this tool, conductor rails can be cut easily to any desired length. Deburring is not necessary because the pliers round off the edges of the rail when cutting.

Type	Part No.	Weight [kg]
Cutting Pliers	081086*	1.500

* Standard range



Tools

Rail straightening tool 081083

To straighten deformed rails:

1. Rail is deformed to a smaller diameter
 - Straighten with ending ①
2. Rail is deformed to a bigger diameter
 - Straighten with ending ②
3. Rail is twisted longitudinal
 - Straighten with ending ③

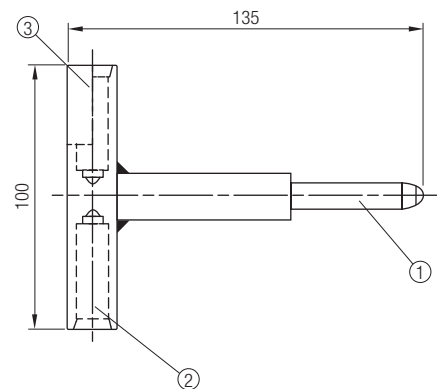

Type	Part No.	Weight [kg]
Rail Straightening Tool	081083*	0.290

* Standard range

Release Pliers 081085

For dismantling the conductor rails the hanger clamps can be spread by these pliers, so that the conductor rails can be easily removed.

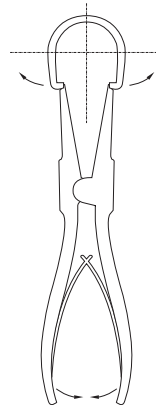

Type	Part No.	Weight [kg]
Release Pliers	081085*	0.160



* Standard range



BB
13-9-03

Conductor Rail Program Summary

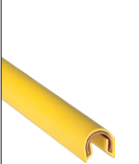
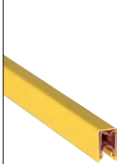
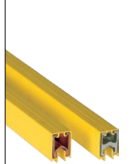
Conductor Rail Program Summary

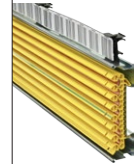
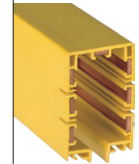
System Type	Single pole insulated conductor rails				Compact conductor rails		Enclosed Rail
Conductor Rail System	Program 0811	Program 0815	Program 0812	Program 0813	Program 0831	Program 0832	Program 0842
							
Rated Current ¹⁾ [A]	10-100	100	25 - 400	200 - 1250	10-125 ³⁾	25 - 200 ⁴⁾	35 - 140 ⁵⁾
Rated Voltage [V]	500	500	660	660	500	690	600
Suspension Spacing [m]	0.4-1.0	0.5	1.5	2.5	1	3.2	2
Rail Length ²⁾ [mm]	4000	4000	4000	5000	4000	4000	4000
Outer Dimensions [mm]	14.7 x 15.5	9.6 x 15.2	18 x 26	32 x 42	3-pole: 26 x 62 4-pole: 26 x 80 5-pole: 26 x 98	4-pole: 200 x 50	5-pole: 56 x 90 7-pole: 56 x 90

1) at 100% duty cycle and 35°C

2) Standard

3) 140 A at 80% duty cycle

4) 200 A at 80% duty cycle

5) 160 A at 80% duty cycle

Note

The images shown are examples. They can differ from the actual product, depending on layout. The validity of the information contained in this catalog is subject to technical changes. In case of technical changes, applications of our products differing from intended use and/or our technical parameters cannot be taken into account. Changes resulting in a loss of functionality in these kinds of applications can only be classified as a warranted feature if Conductix-Wampfler has issued a written approval.

We reserve the right to carry out modifications to the product in the course of technical development any time without prior notice.

According to machine directives, conductor rails are regarded as partly completed machinery. Commissioning is only permissible if the higher-level machine in which the conductor rail is installed complies with regulations. Our general terms and conditions apply. These can be obtained from us on request, or you can find them on our website: www.conductix.com. This catalogue, or parts of it, may be copied or reprinted only with our permission.

Custom services

Need more?

When you're talking to us about conductor rails, there's more!
Whether you need more information, are looking for a solution to fit your needs, or require support on-site. We speak your language.

Talk to us – we have a solution for you!



Conductix-Wampfler's specialists provide complete support from the initial programming and design to the final assembly on site – worldwide!



Project planning

- Handling task specifications and parameters, and the layout of the system

Commissioning and preliminary assembly

- Preliminary assembly and assembly-oriented packaging.



Assembly and commissioning

- Installation, commissioning, and training by our technicians before being handed over to the customer

Rental service and supervisor

- Provision of assembly systems and special tools for the efficient installation of our systems
- Support as needed by an experienced supervisor from our service team

Service and maintenance

- Regular inspection of the system, replacement of wearing parts
- Cleaning and testing
- Assembly and maintenance training
- Supervision

Your applications – our Solutions

Conductor rails are just one component of the many solutions from the broad spectrum of Conductix-Wampfler energy, data, and handling systems. Which solution is the right one for your application always depends on the specific application situation. A combination of multiple Conductix-Wampfler products often provides very attractive advantages. Consulting and engineering competence are at your command in our companies and representatives around the world – as well as our solutions!



Cable reels
Motorized and spring cable reels from Conductix-Wampfler have their place wherever energy, data and media must travel a wide variety of distances in a short time – in any direction, quickly and safely.



Festoon systems
Conductix-Wampfler festoon systems are a fixed part of any industrial application: reliable and robust and available in an enormous variety of dimensions and variants.

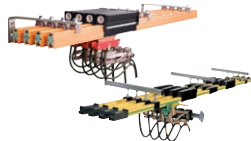

Conductor rails
Whether they're a box conductor rail or an extendible single-pole system, familiar Conductix-Wampfler conductor rails get people and material moving reliably.

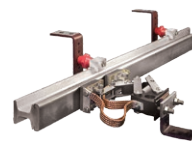

Non-insulated conductor rails
Extremely robust, non-insulated conductor rails with copper head or stainless steel support surface are the ideal basis for harsh use e.g. in steel plants or ports.

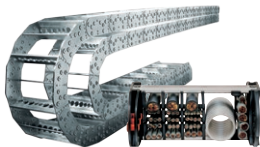

Energy chains
The jack-of-all-trades when it comes to energy, data and media transfer. With the breadth of their product range, energy chains have a permanent place in industrial applications.



Slip ring bodies
Wherever things have to be smooth and round, tried and trusted slip ring bodies from Conductix-Wampfler provide interruption-free energy and data transmission. The focus here is on flexibility and reliability!



Inductive Power Transfer IPT®
The contact-free system for energy and data transmission. For high speeds absolutely free of wear.



Take-up reels and spring balancers
Whether for hoses or cables, as classic take-up reel or high-precision positioning aids for tools – take-up reels and spring balancers from Conductix-Wampfler take the load off you.



Jib booms
Installed with tool transporters, trolleys or complete media feed – safety and flexibility are brought together here when handling tough tasks.



Conveyor systems
Whether manual, semiautomatic or with Power & Free – a high degree of individuality is guaranteed when it comes to layout requirements and the place of use.

www.conductix.com

Conductix-Wampfler

has just one critical mission:

To provide you with energy and data transmission systems that will keep your operations up and running 24/7/365.

To contact your nearest sales office, please refer to:

**[www.conductix.com/
contact-search](http://www.conductix.com/contact-search)**



DELACHAUX GROUP